

Gap Labeling

Nick (Noseguard) Always Counts 4 Men From End Man on LOS
The Snapper is not Always the Center of the Line!

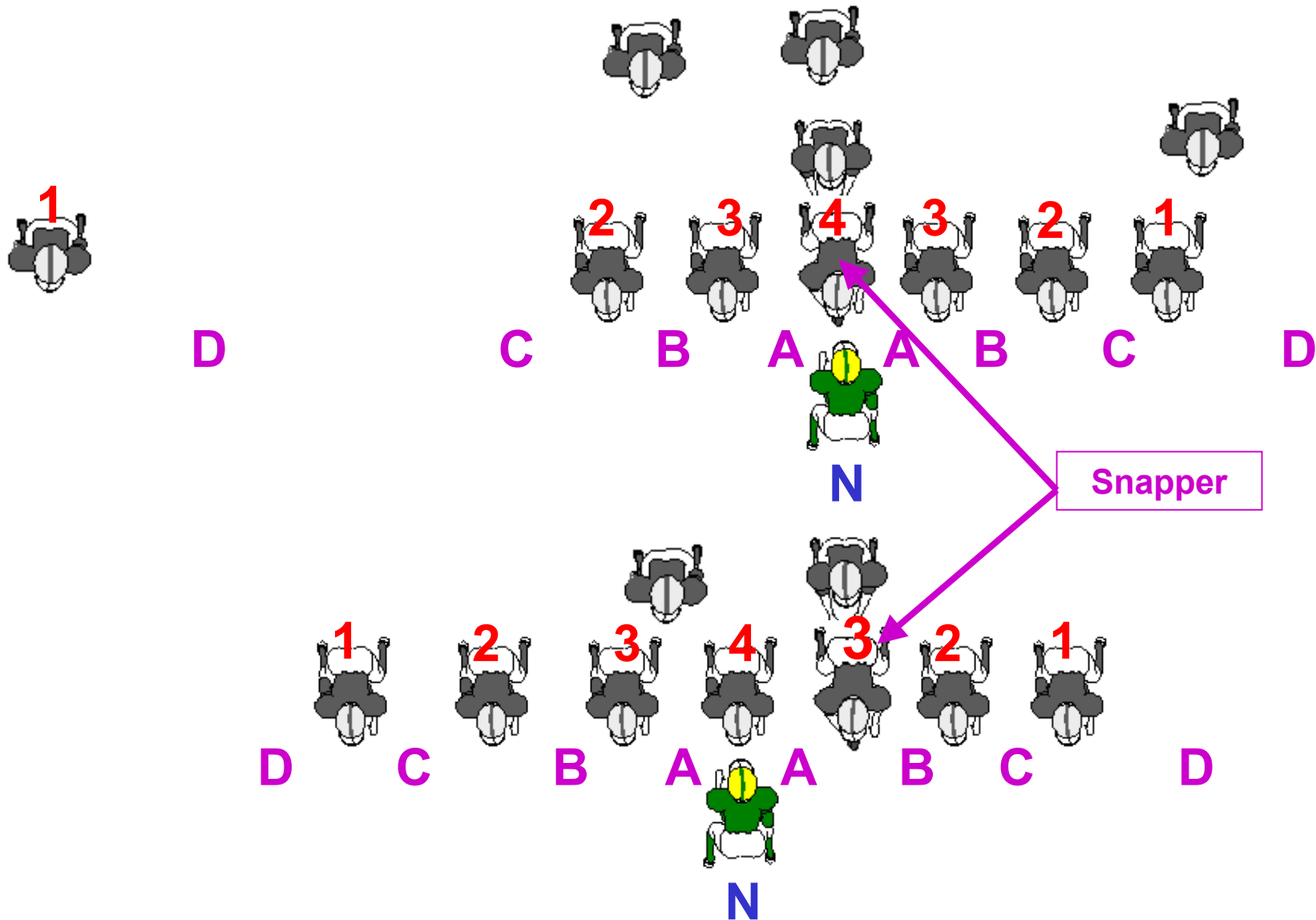

Wing-T Offense

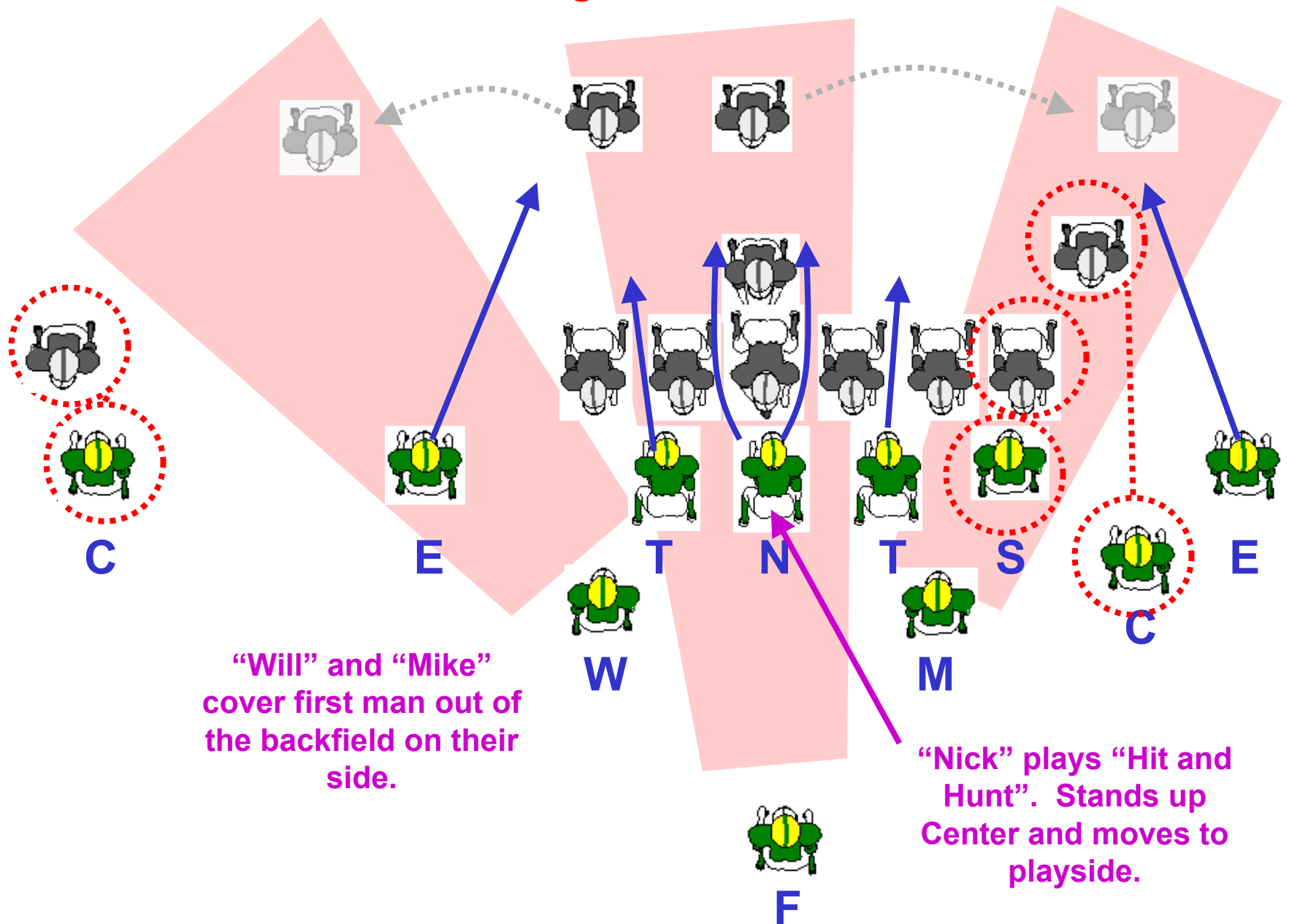

“Will” and “Mike” cover first man out of the backfield on their side.

“Nick” plays “Hit and Hunt”. Stands up Center and moves to playside.

Slot Wing-T Offense

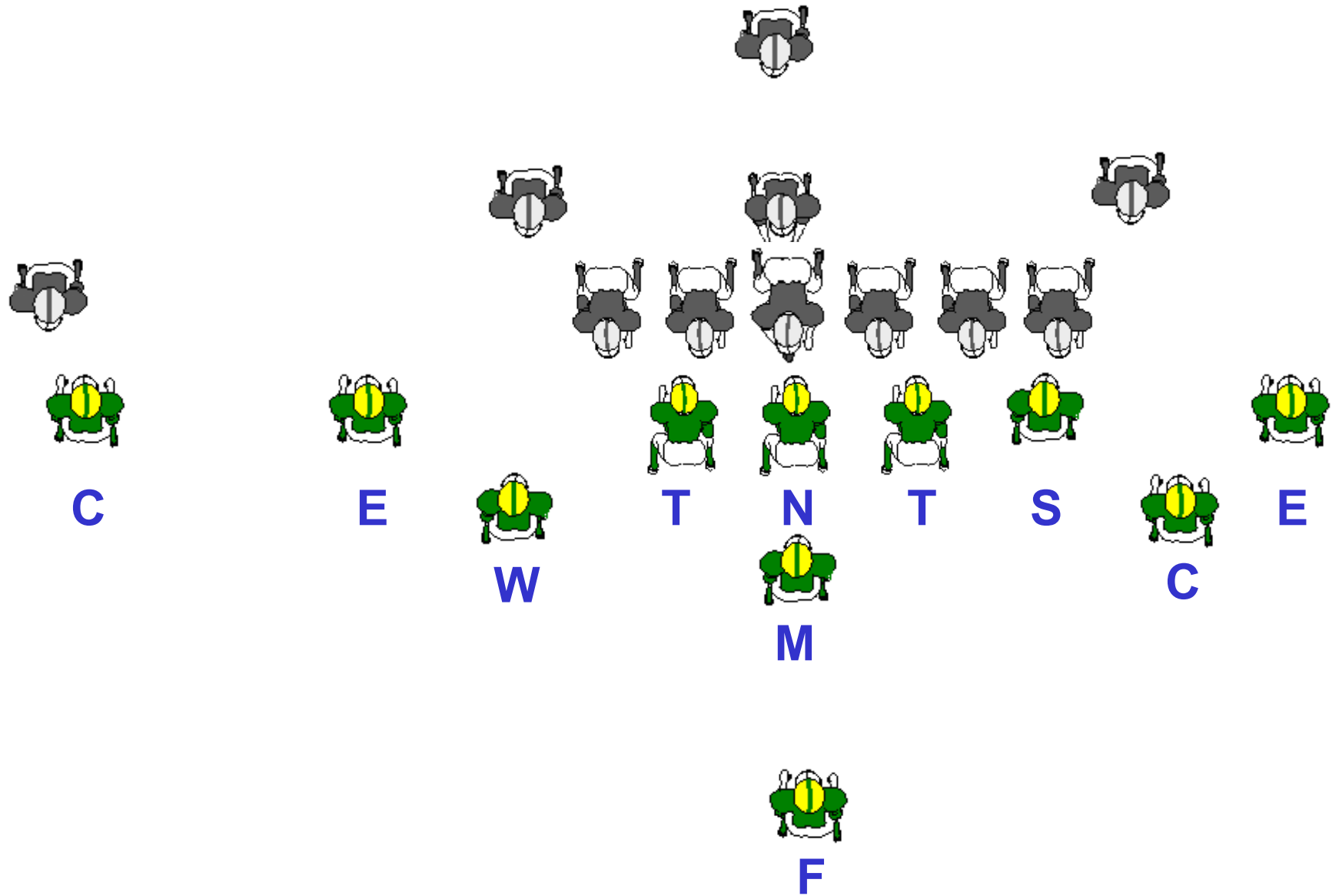

Double Tight Wing-T Offense

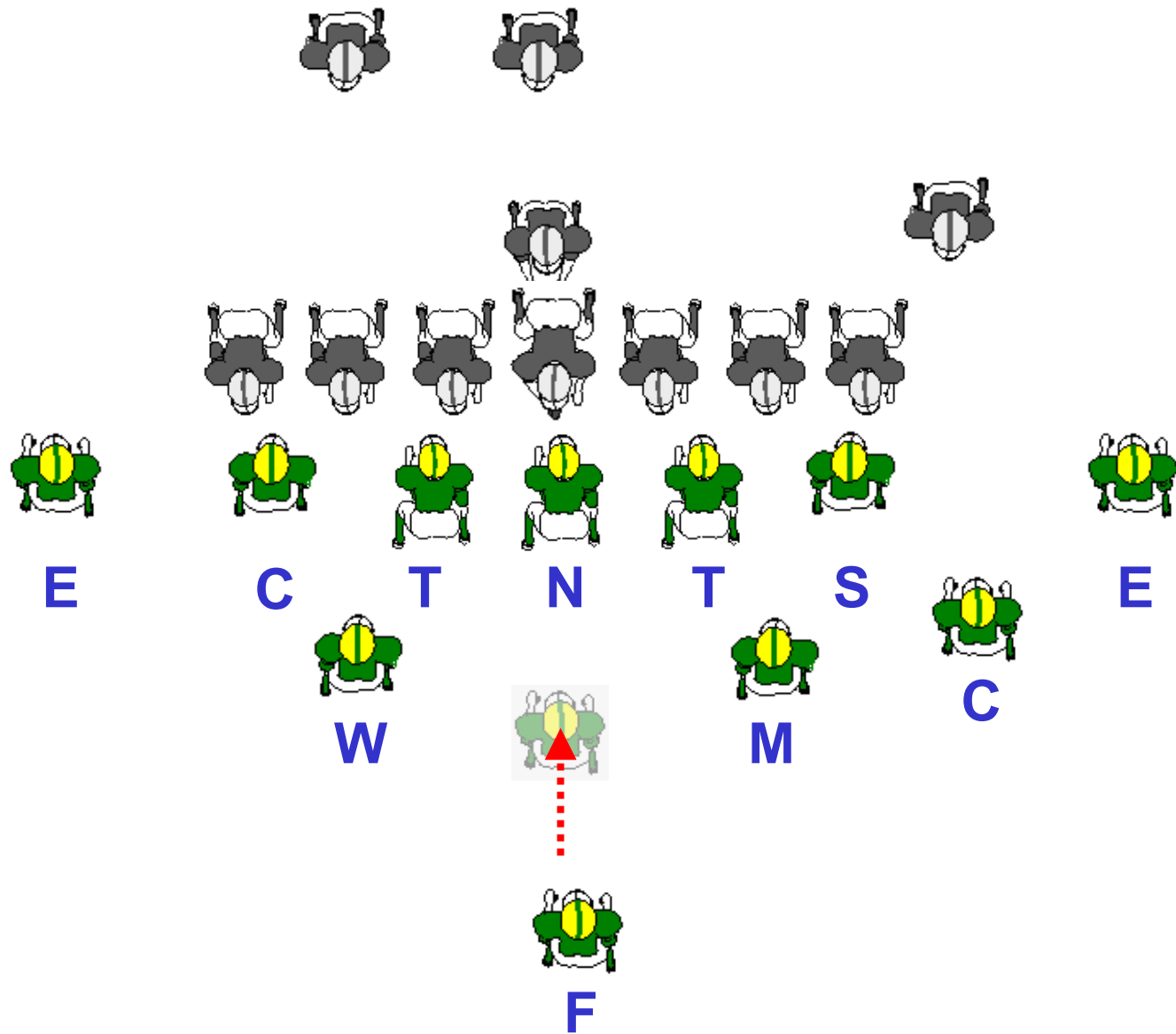

Double Tight Wing-T Offense

“CLAW” Adjustment
Use when TE is
overpowering
Cornerback. Switch DE
and CB

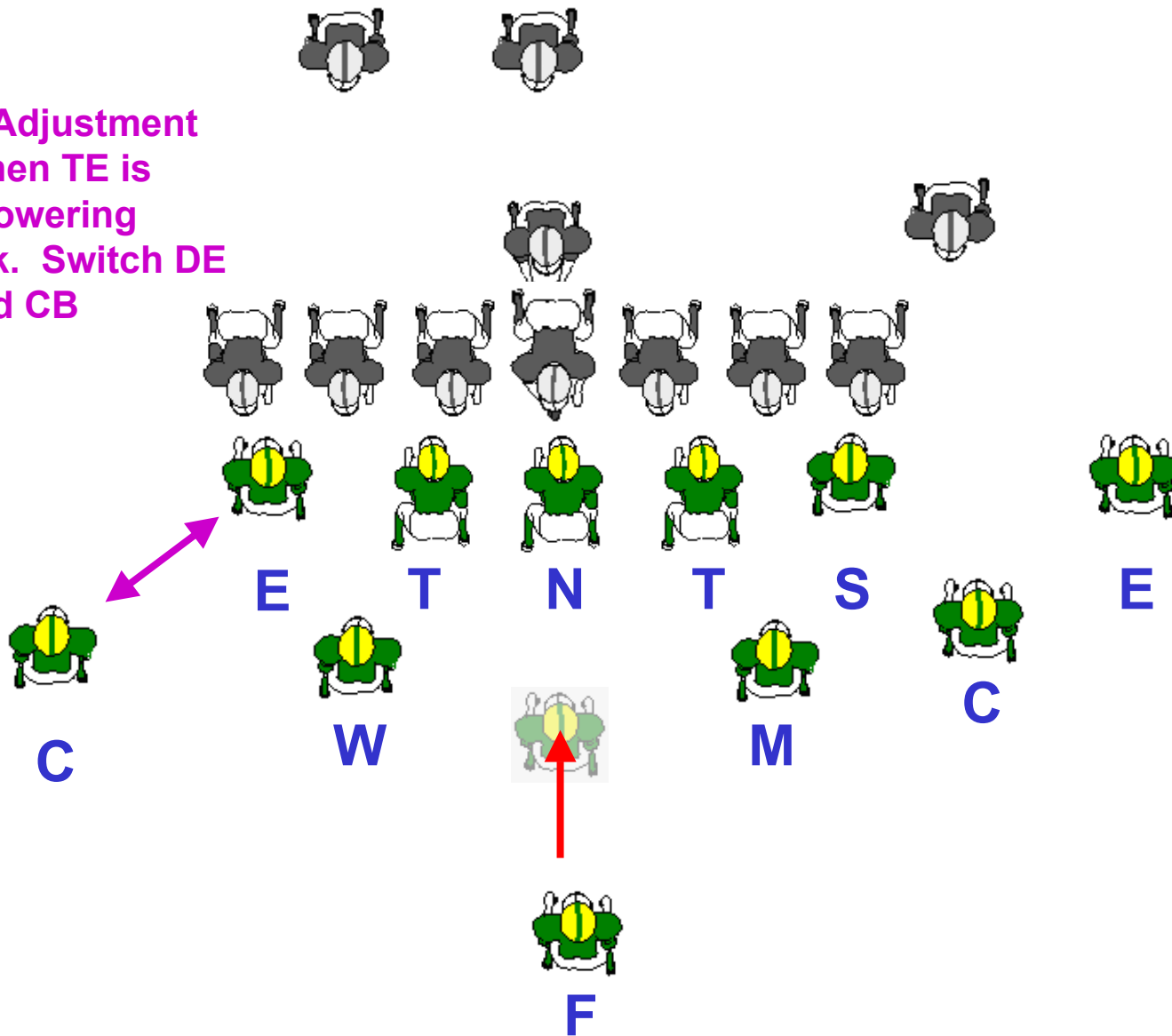

Double Wing Offense

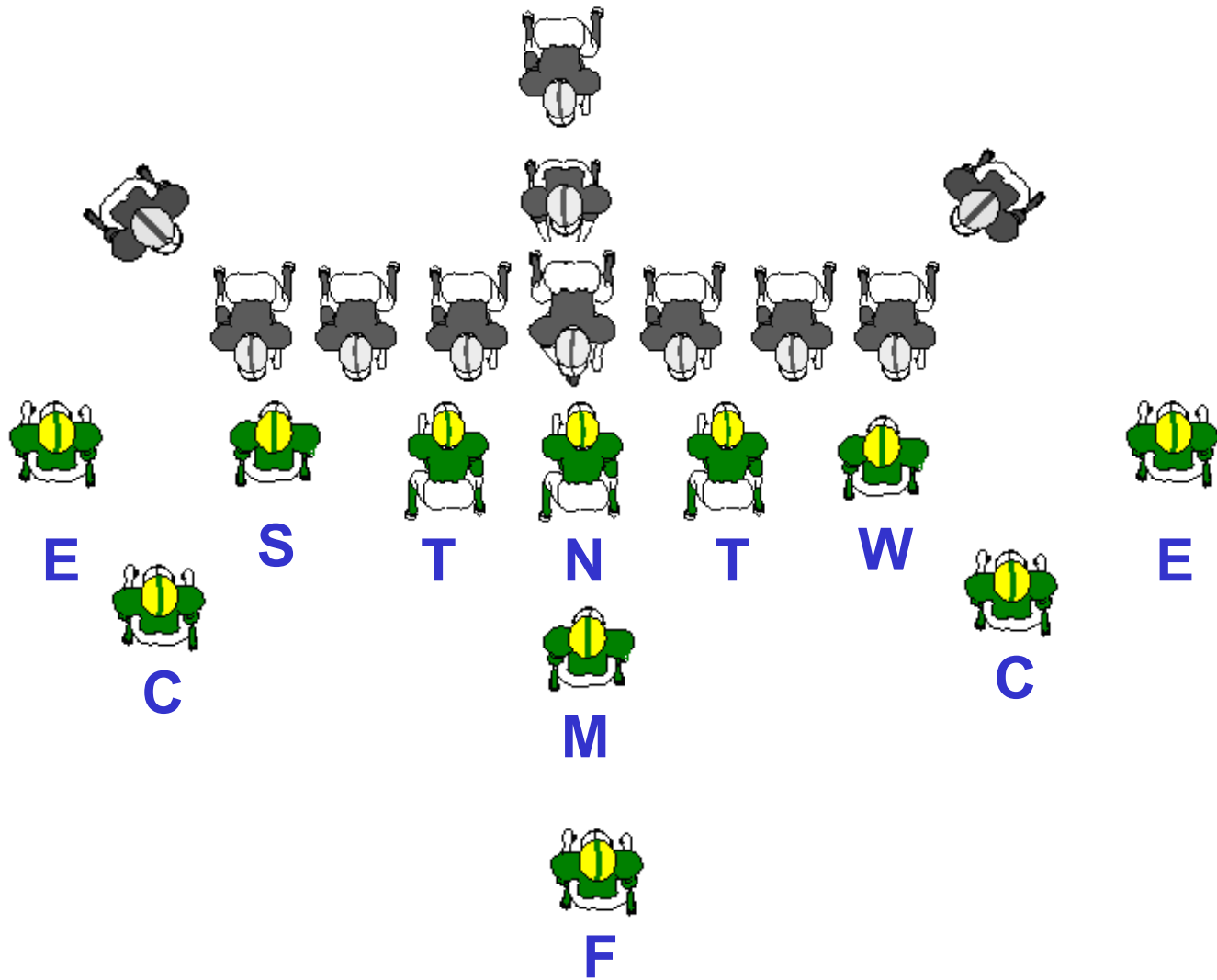

Double Wing Offense

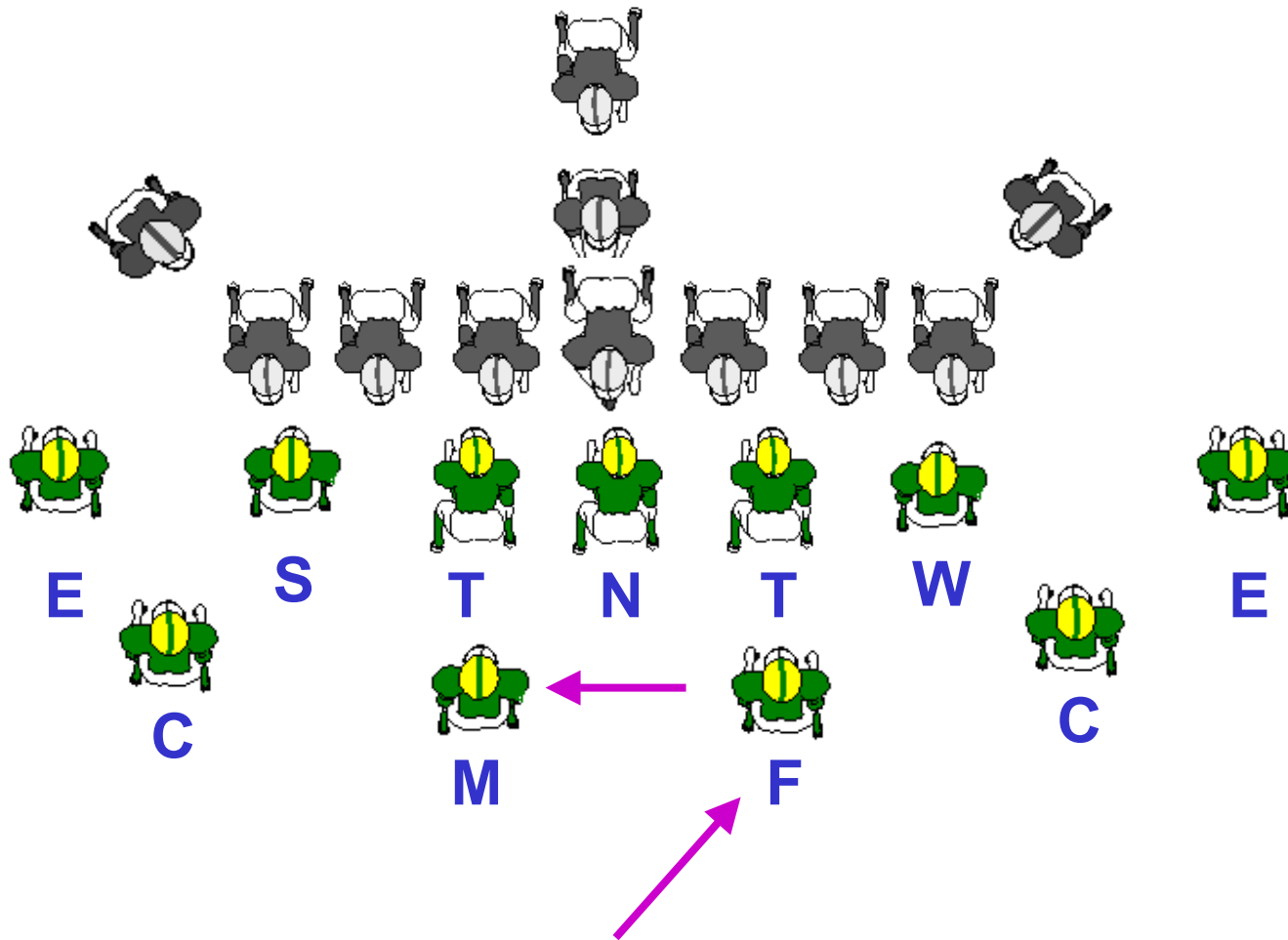

“TOUGH” Call
Move Mike over and
bring Fred up.

Double Wing Offense

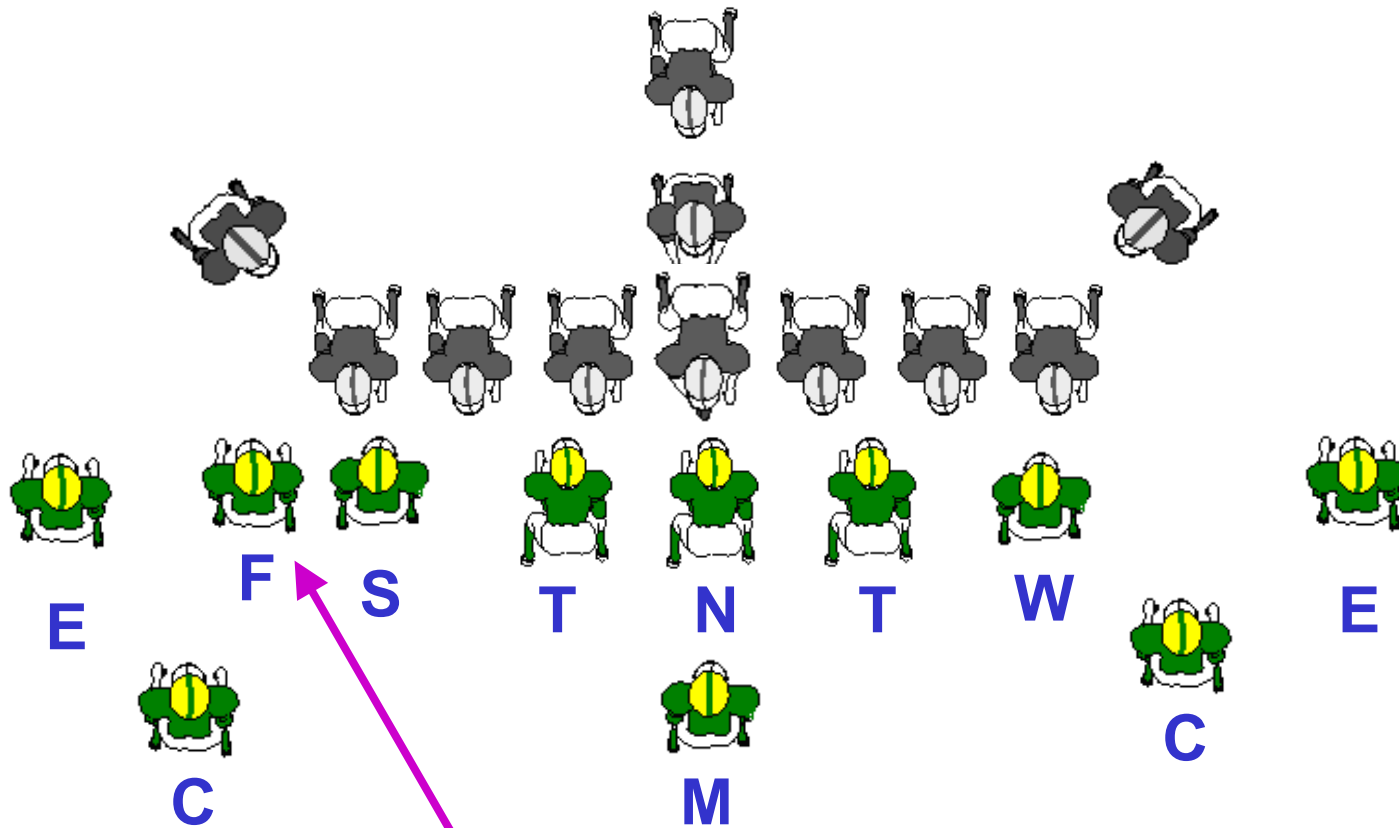

“STONE” Call

Move Fred up and double-team the TE on the side you think they are running to.

(This would be “Fred/Sam Stone”)

Could use other pairs such as “End/Sam Stone”

Power | Offense

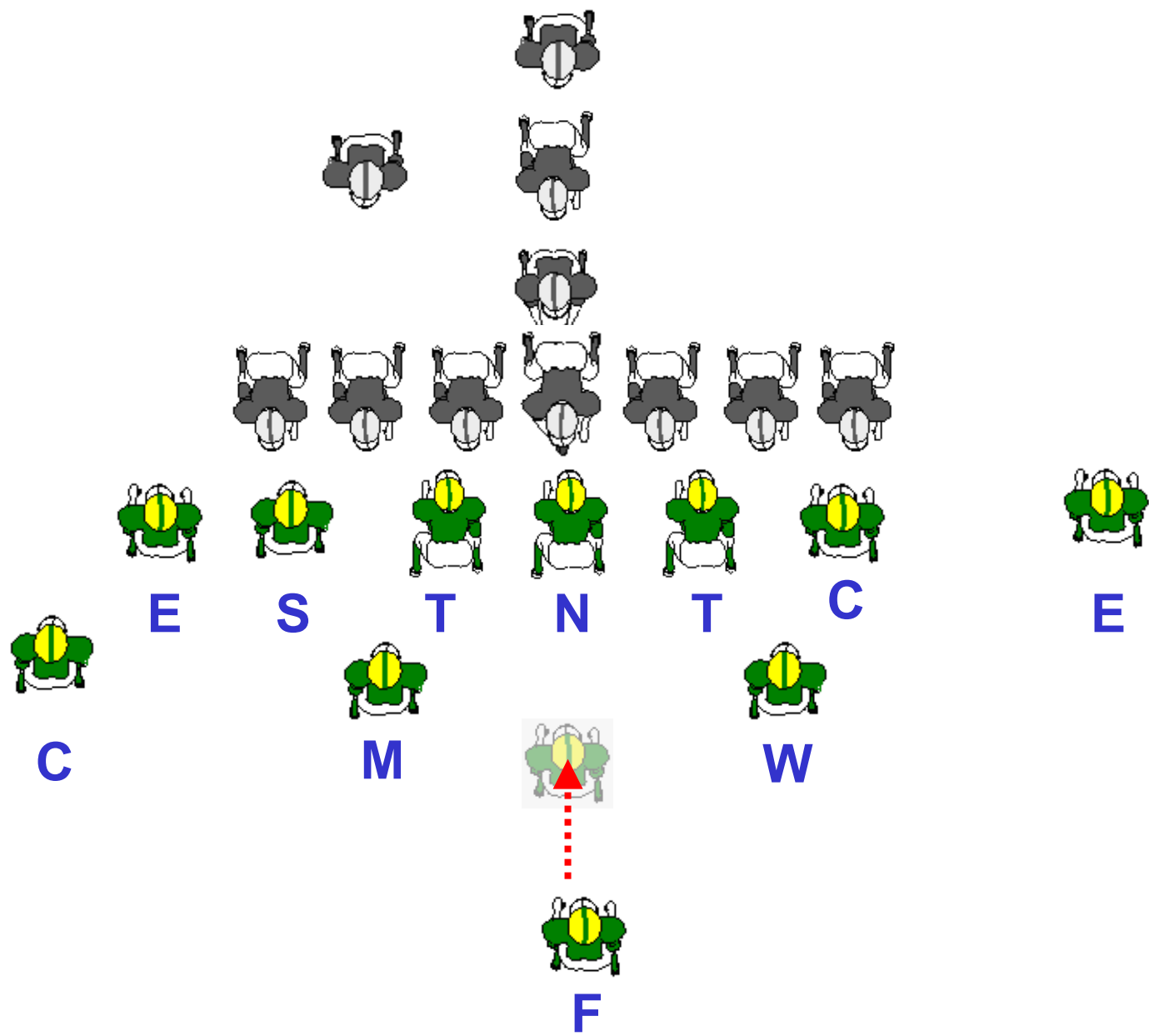

Wishbone Offense

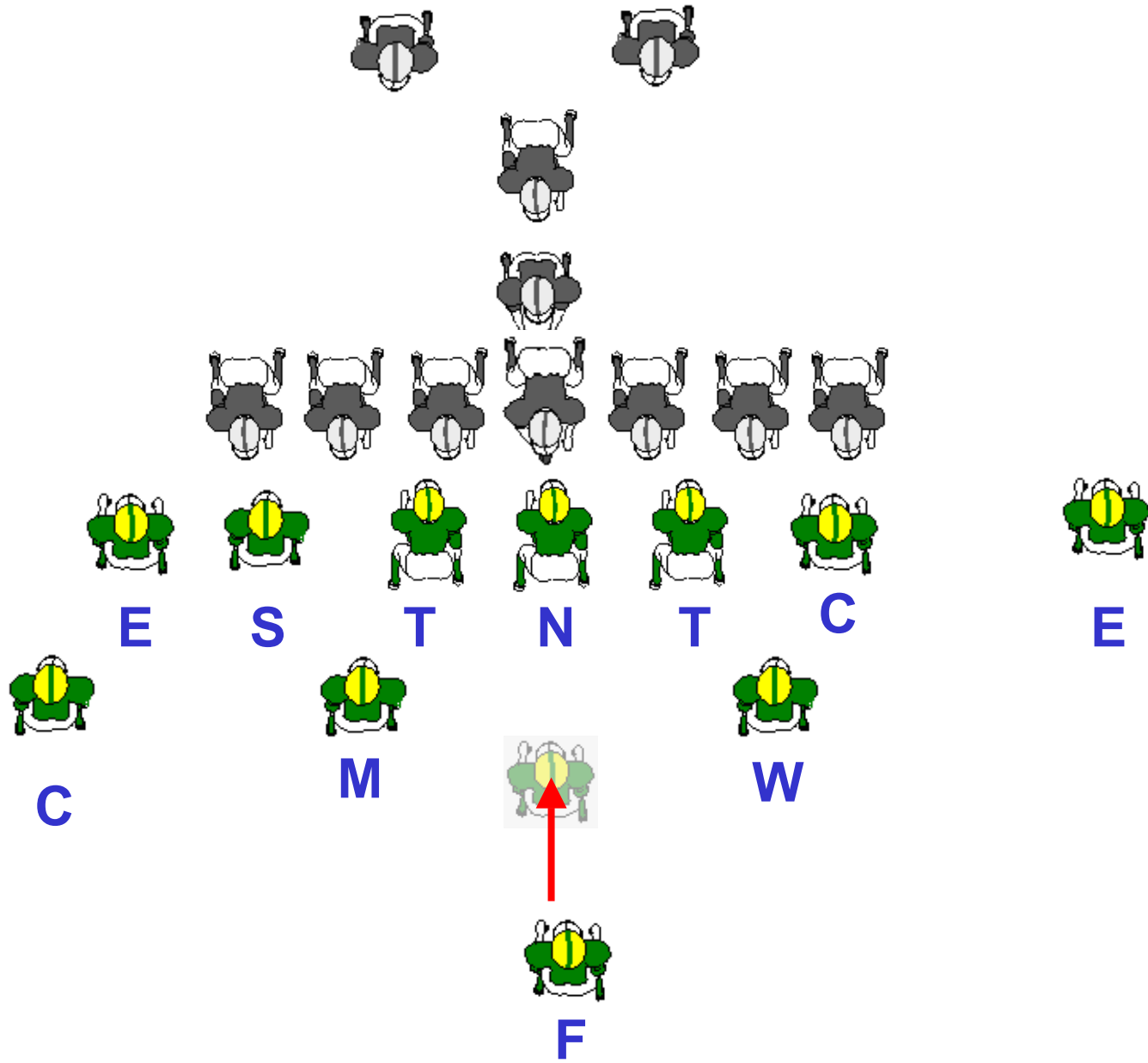

Pro-Set Offense

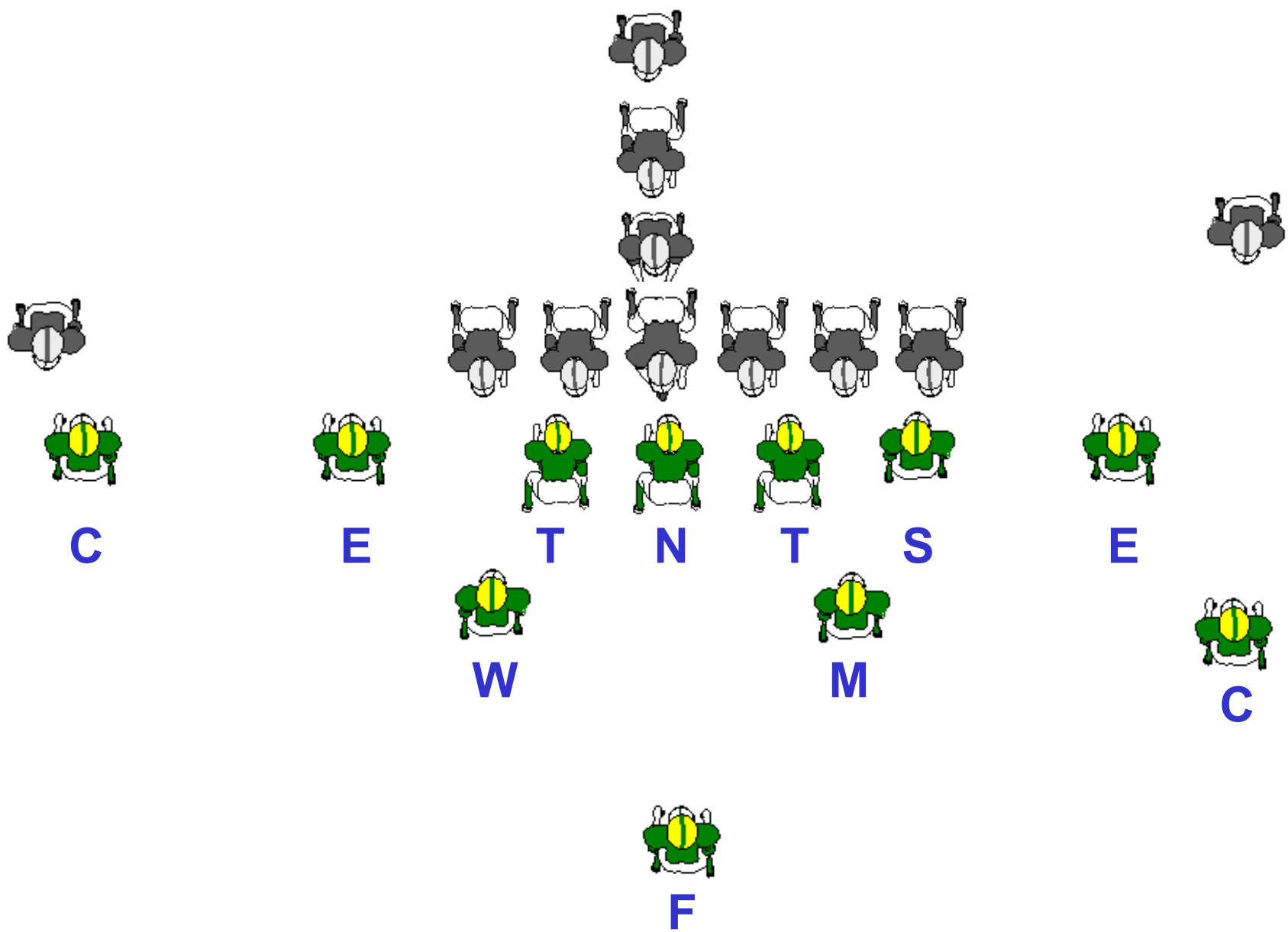

One Back Set Offense

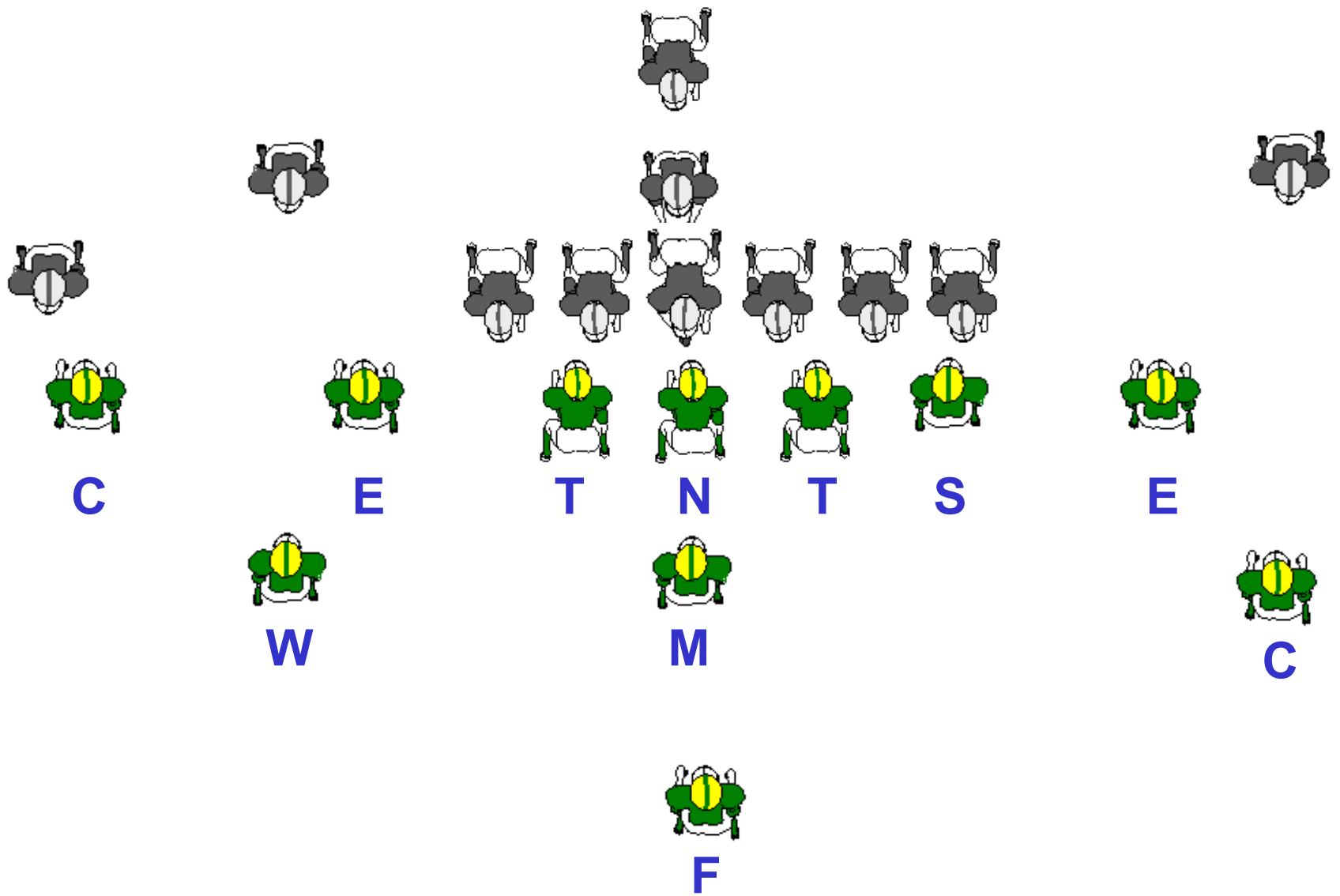

“Trips” Offense With Tight End

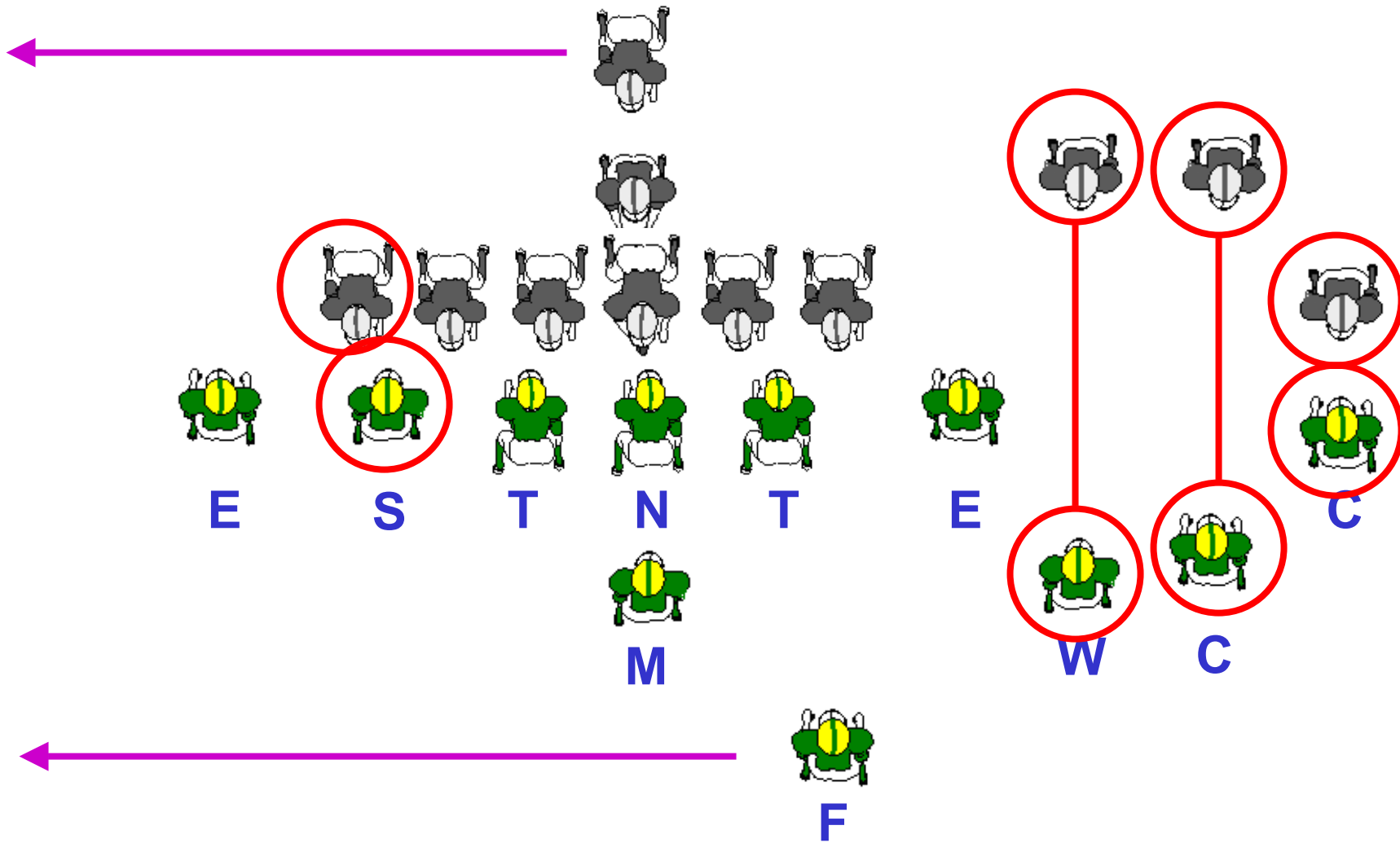

“Trips” Offense No Tight End

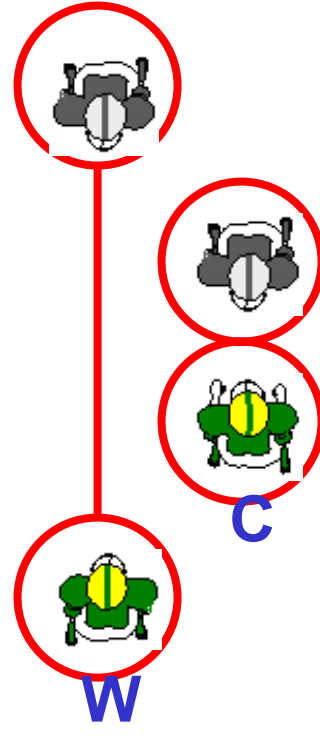
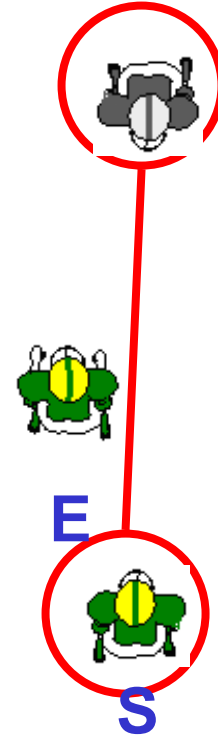
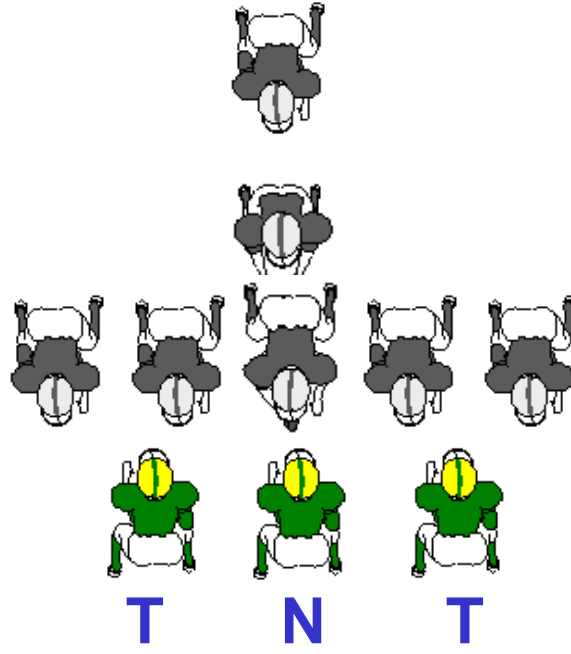
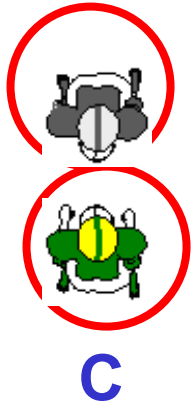

Spread Offense

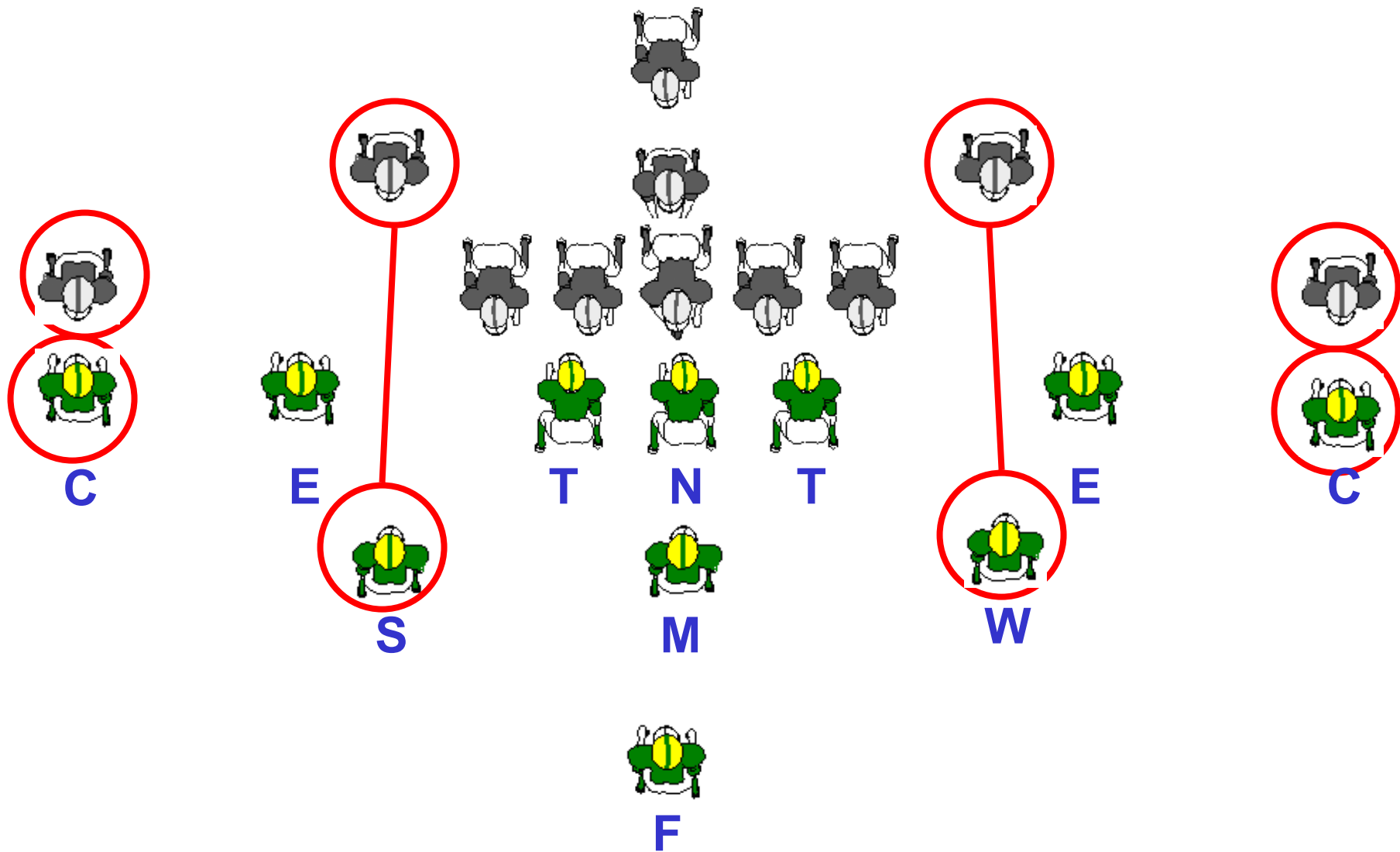

Shotgun Formation "Spy Coverage"

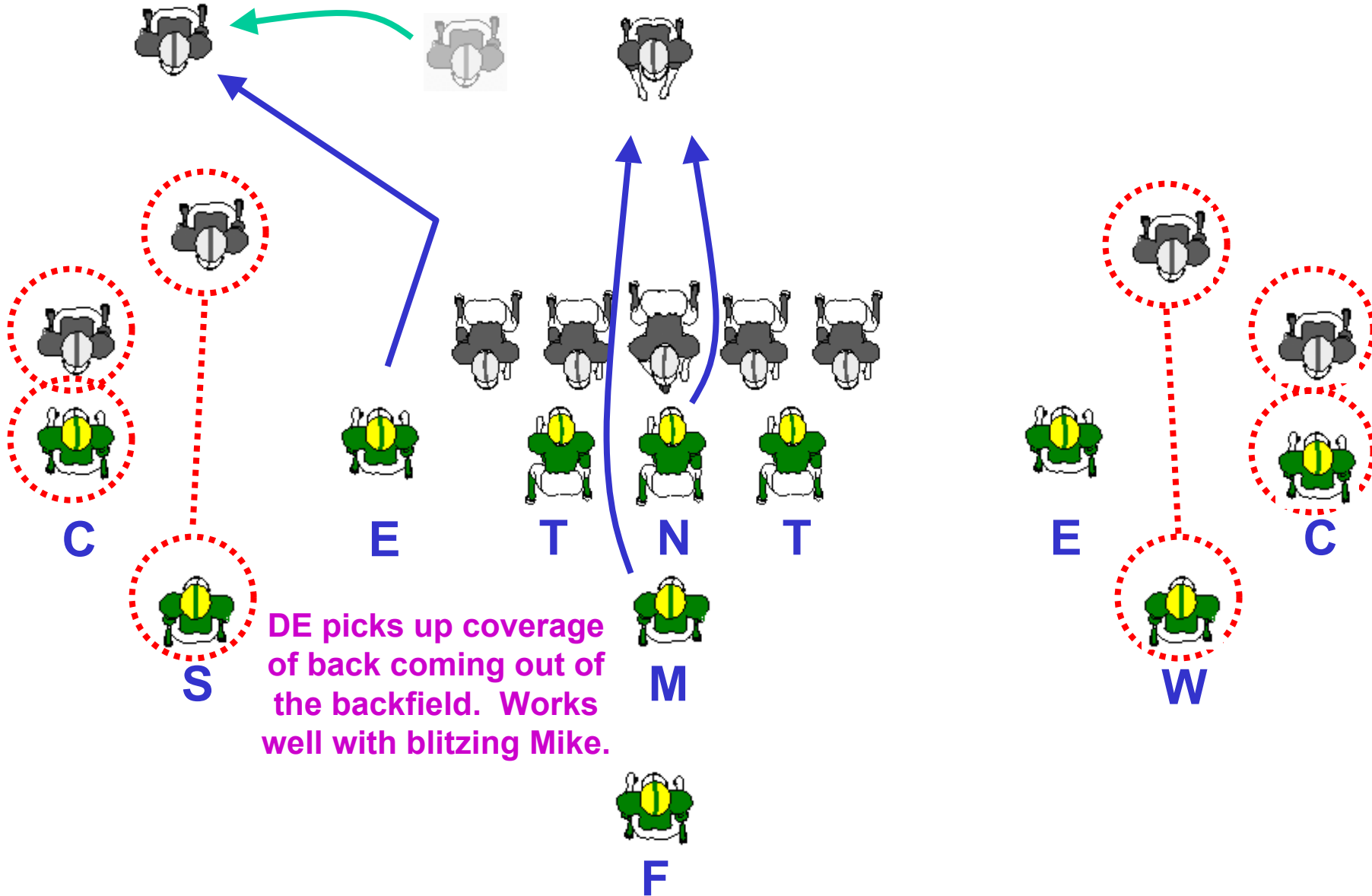

Single Wing Offense

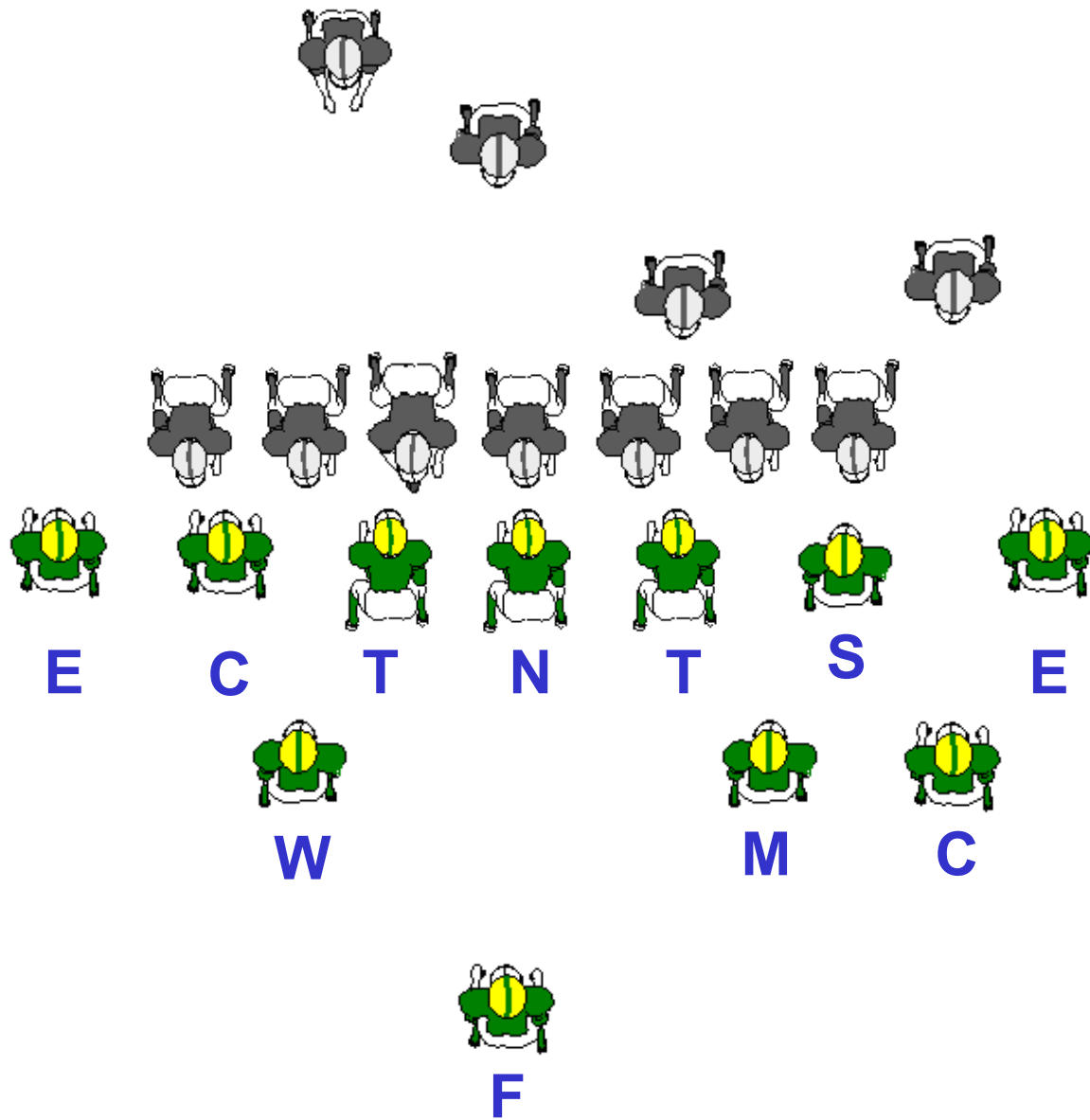

“NICK Right” Call Wing-T Offense

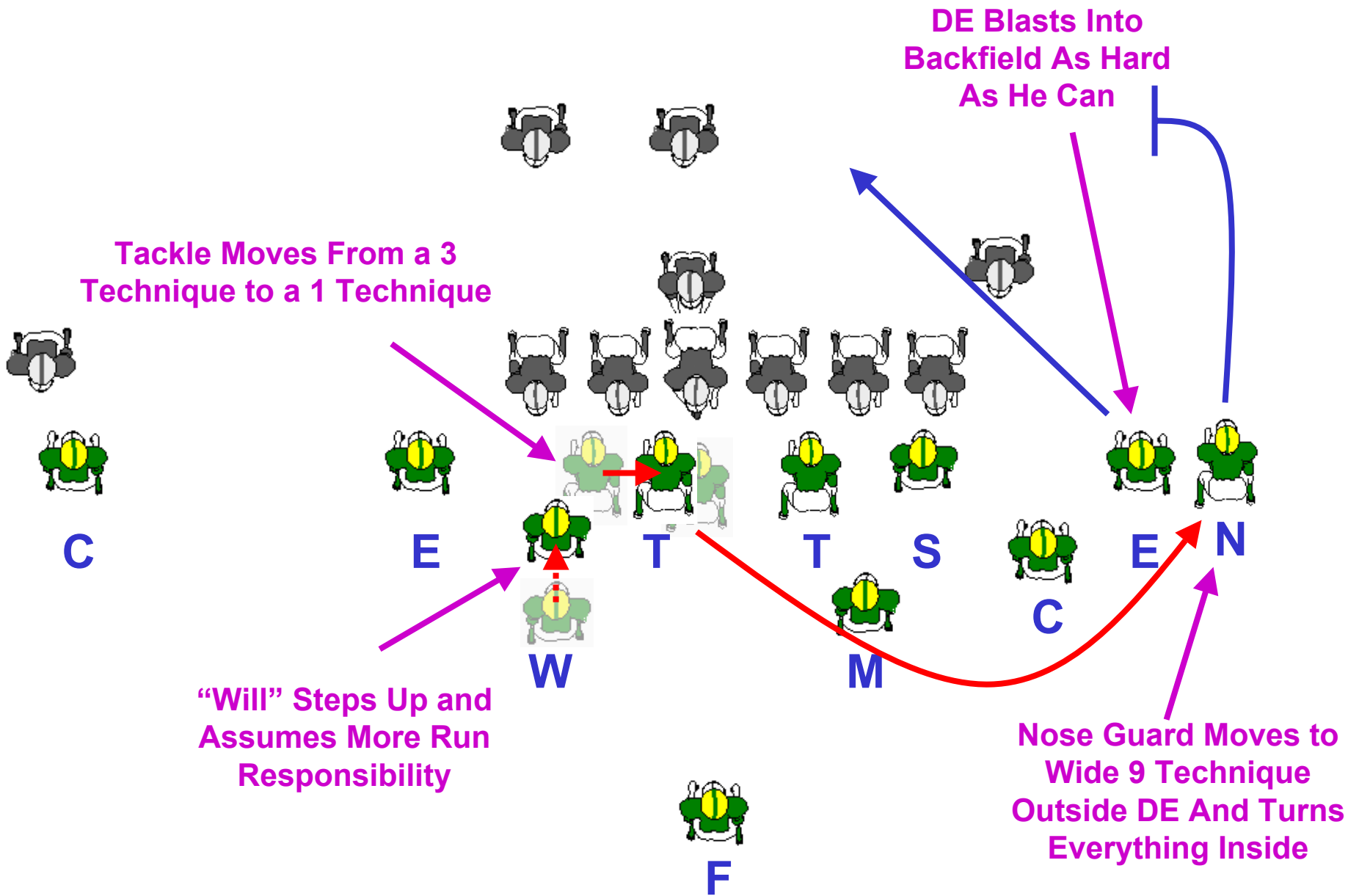

“HAWK” Call Wing-T Offense

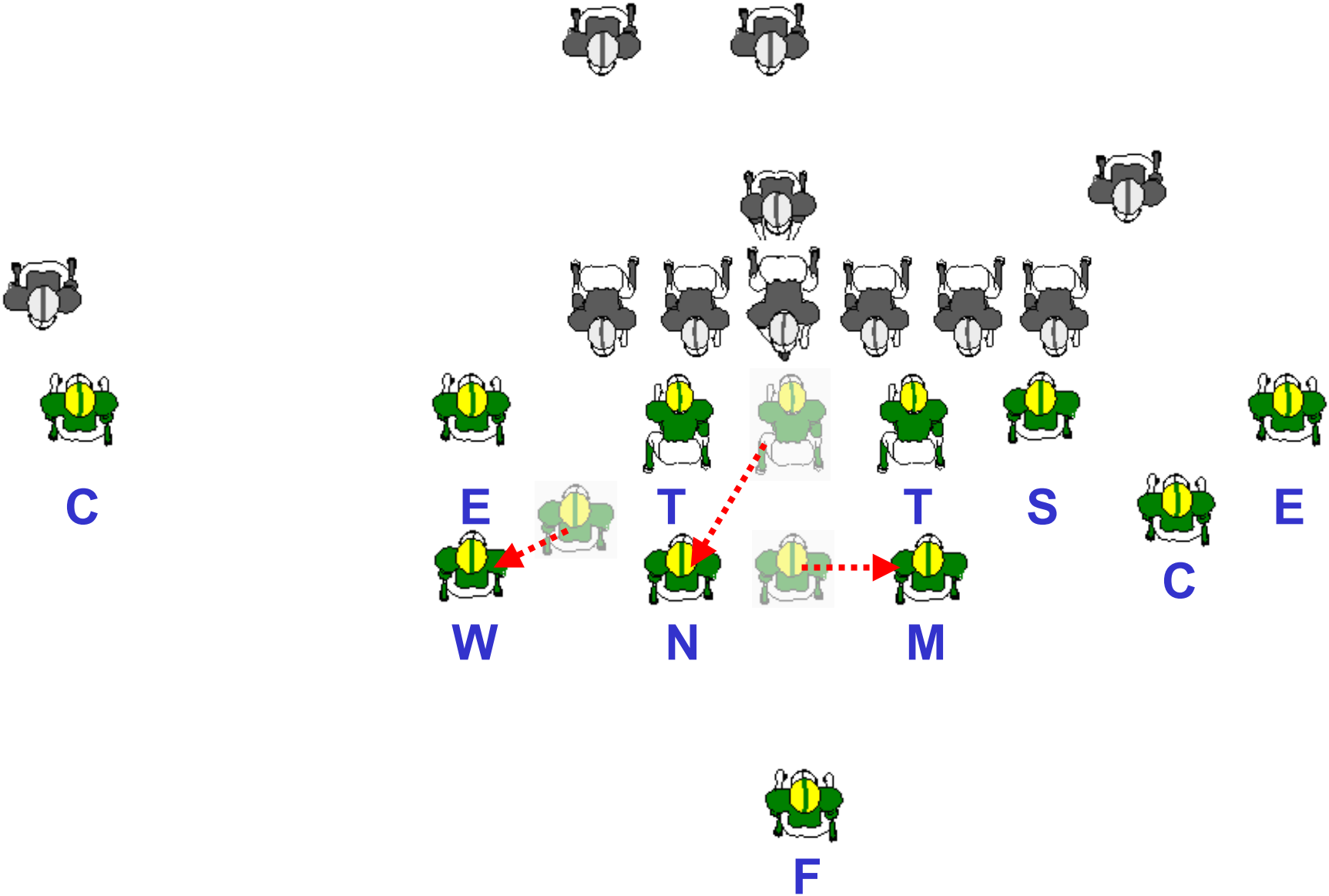

“Victory” Call Wing-T Offense

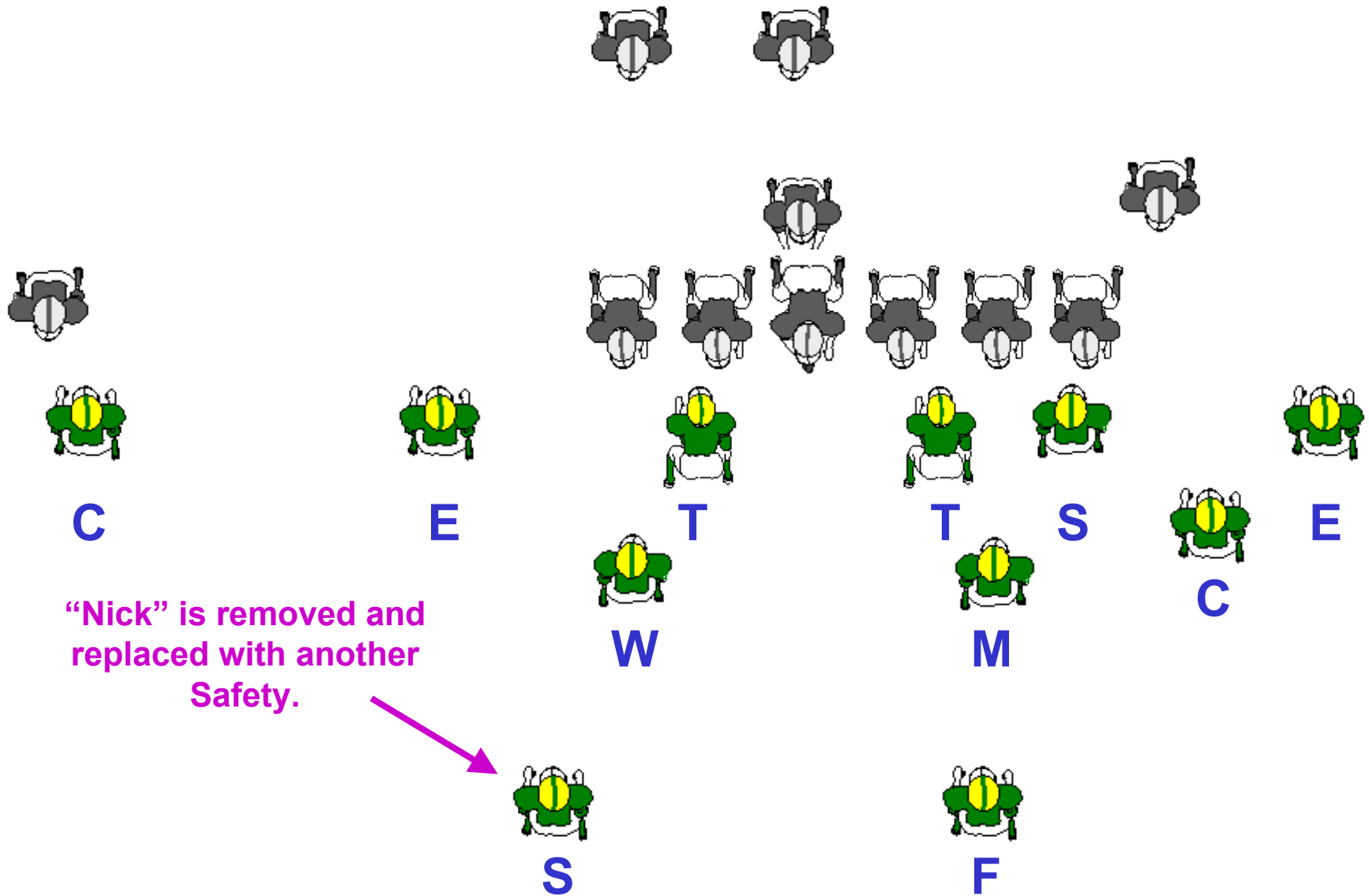

“Mike” Call Wing-T Offense

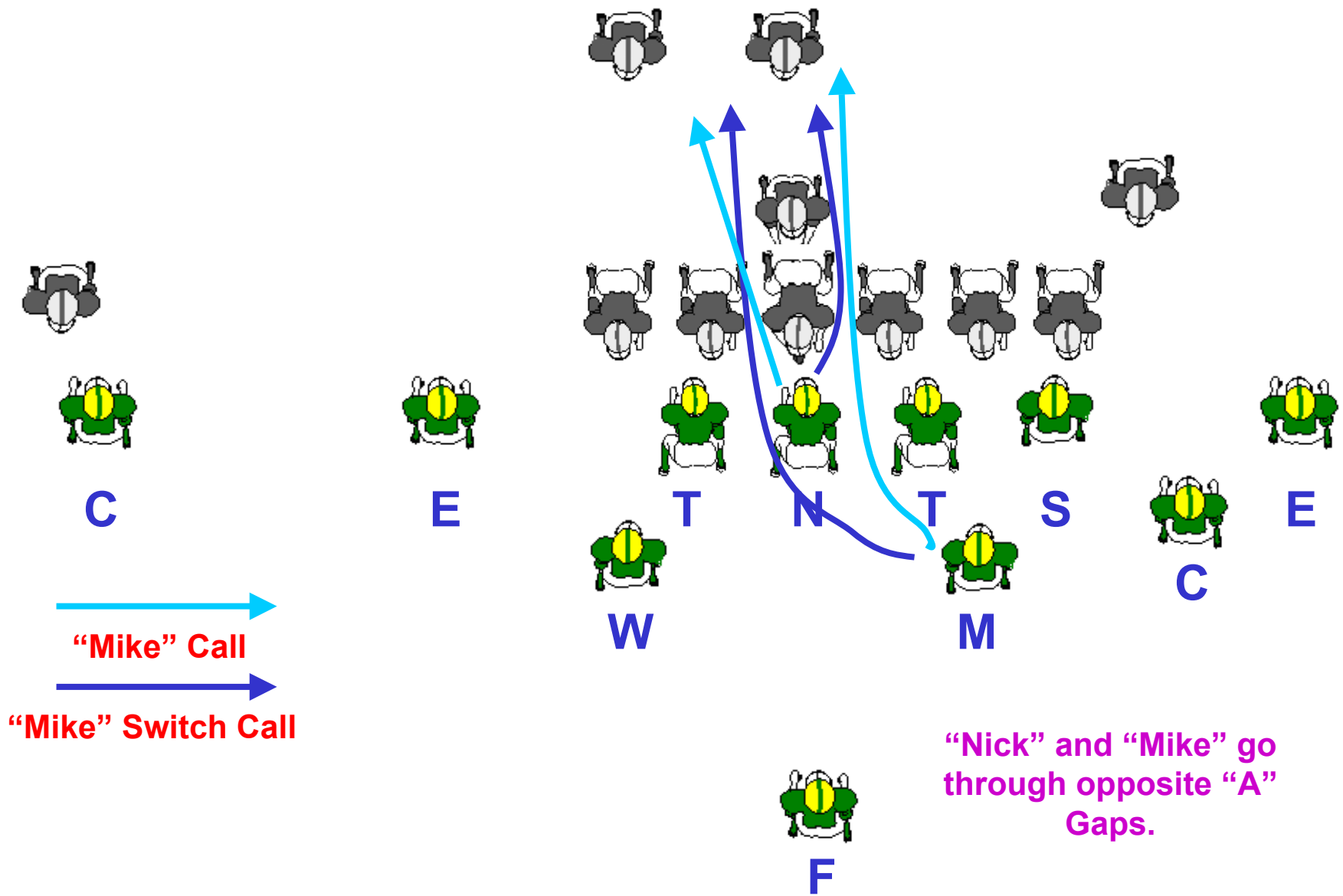

“Mikey” Call Wing-T Offense

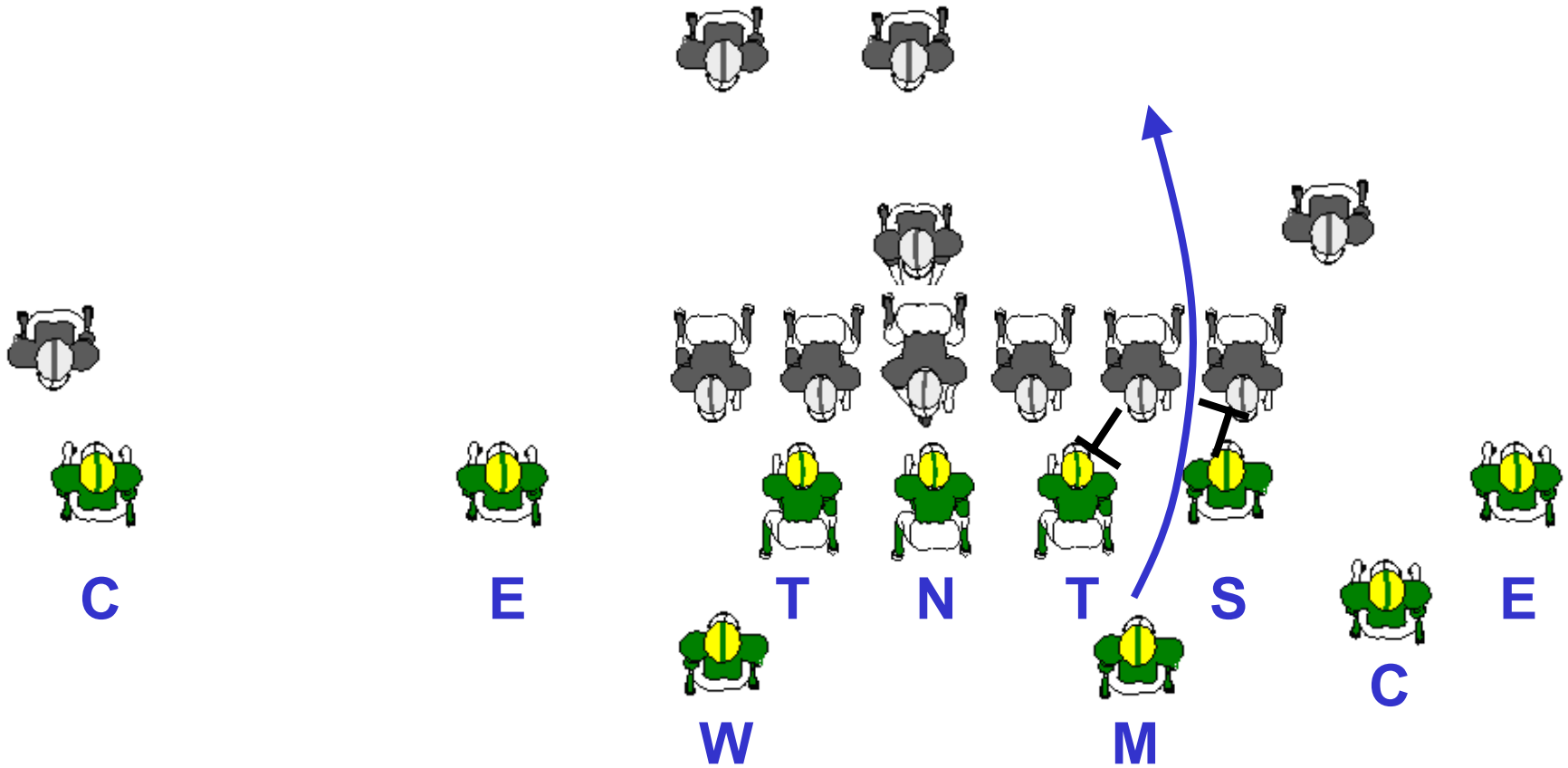

“Mike” goes through
“C” Gap if OT is
downblocking DT.
“Sam” blocks TE out.

“Will” Call Wing-T Offense

“Nick” and “Will” go through opposite “A” Gaps.

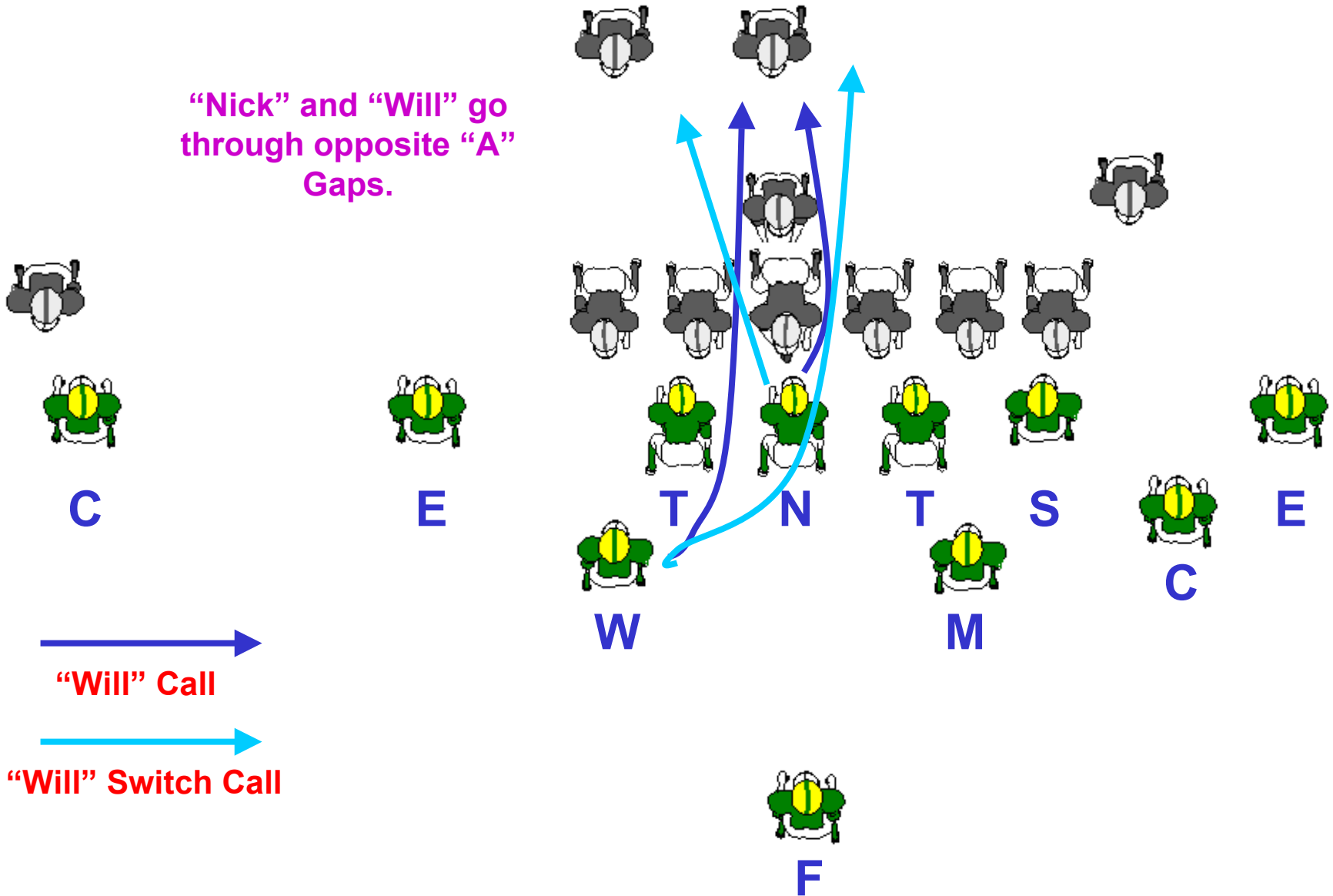

“Willie” Call Wing-T Offense

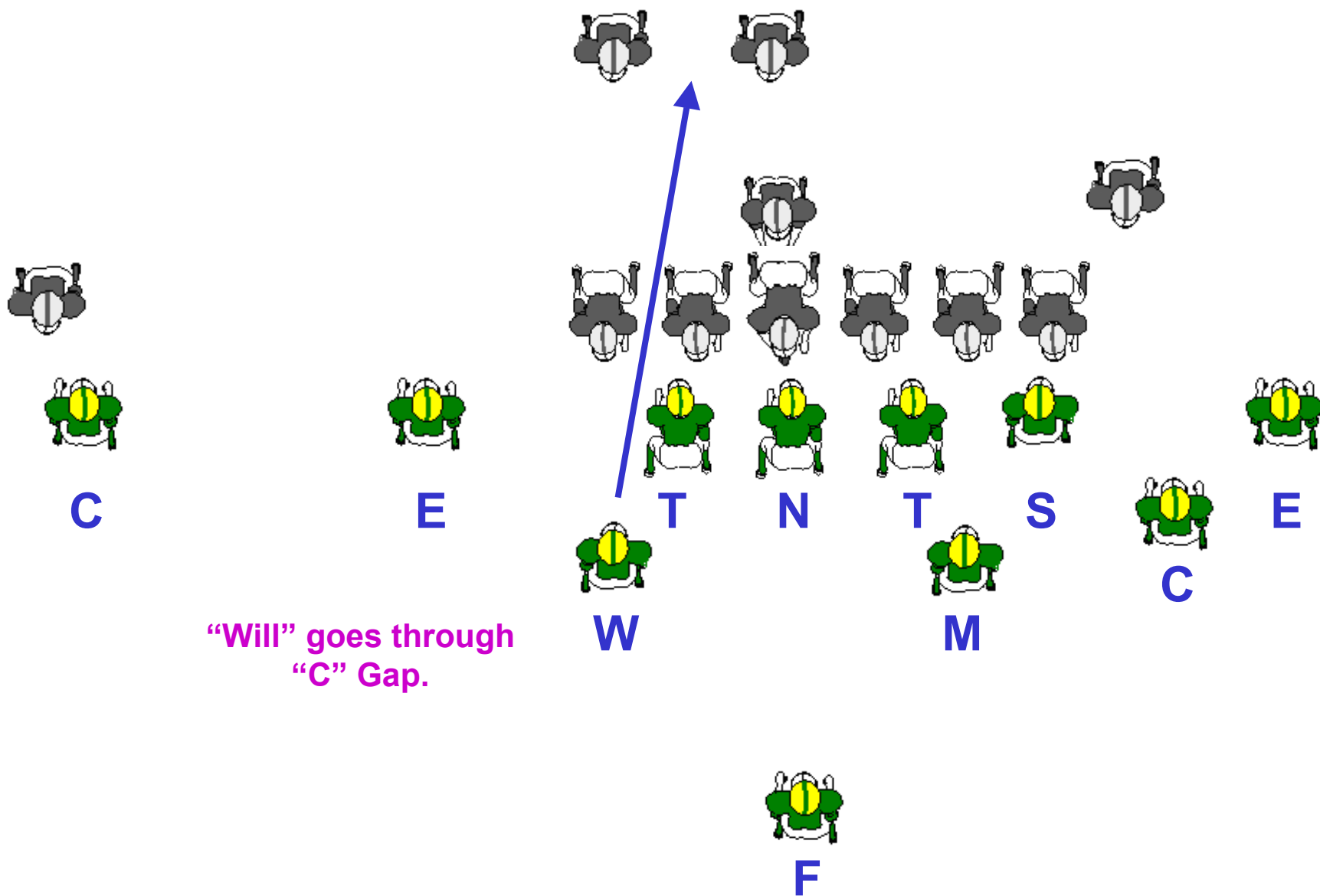

“Sam” Call Wing-T Offense

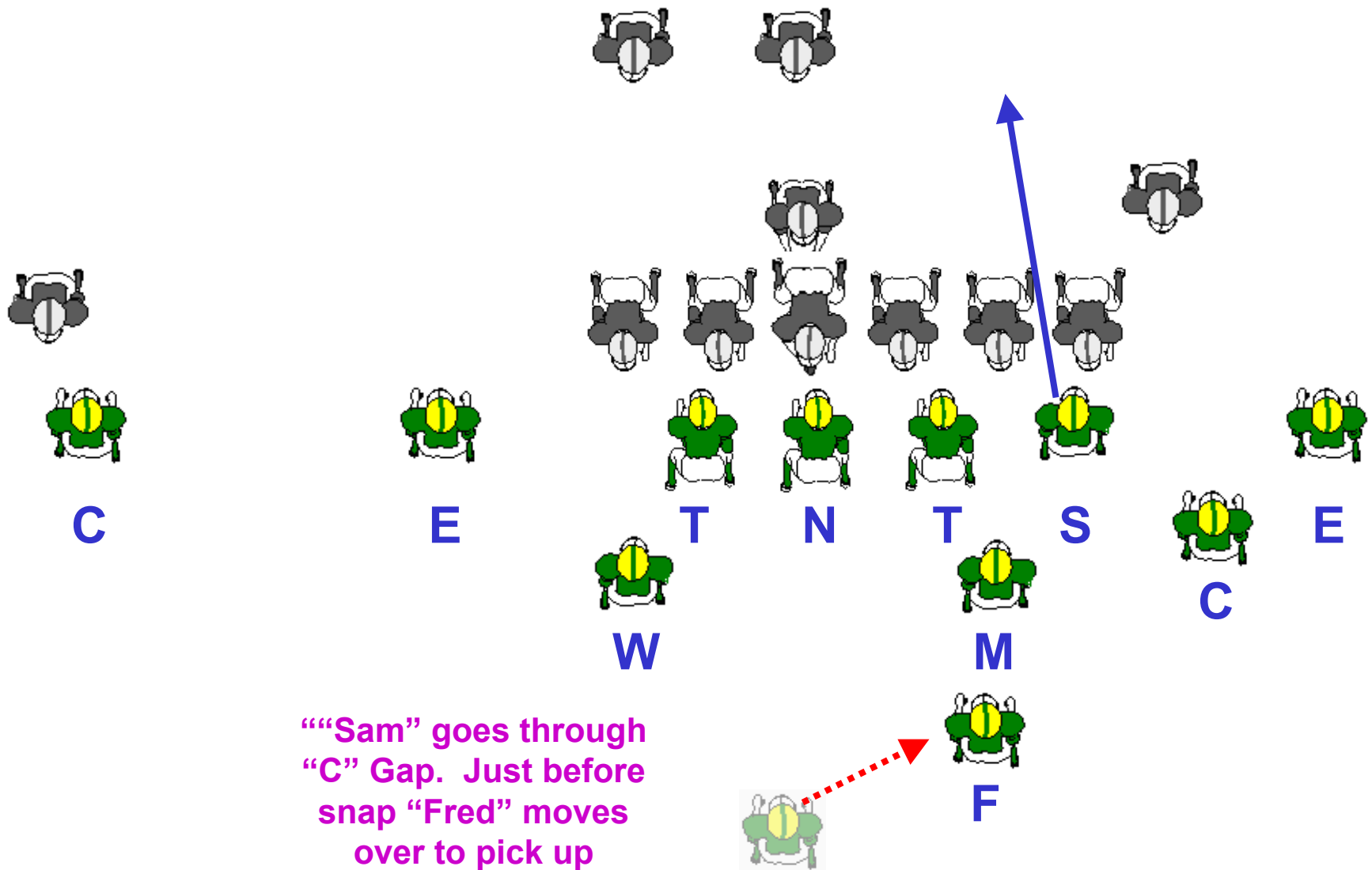

“Sam” goes through
“C” Gap. Just before
snap “Fred” moves
over to pick up
coverage of TE.

“Samson” Call Wing-T Offense

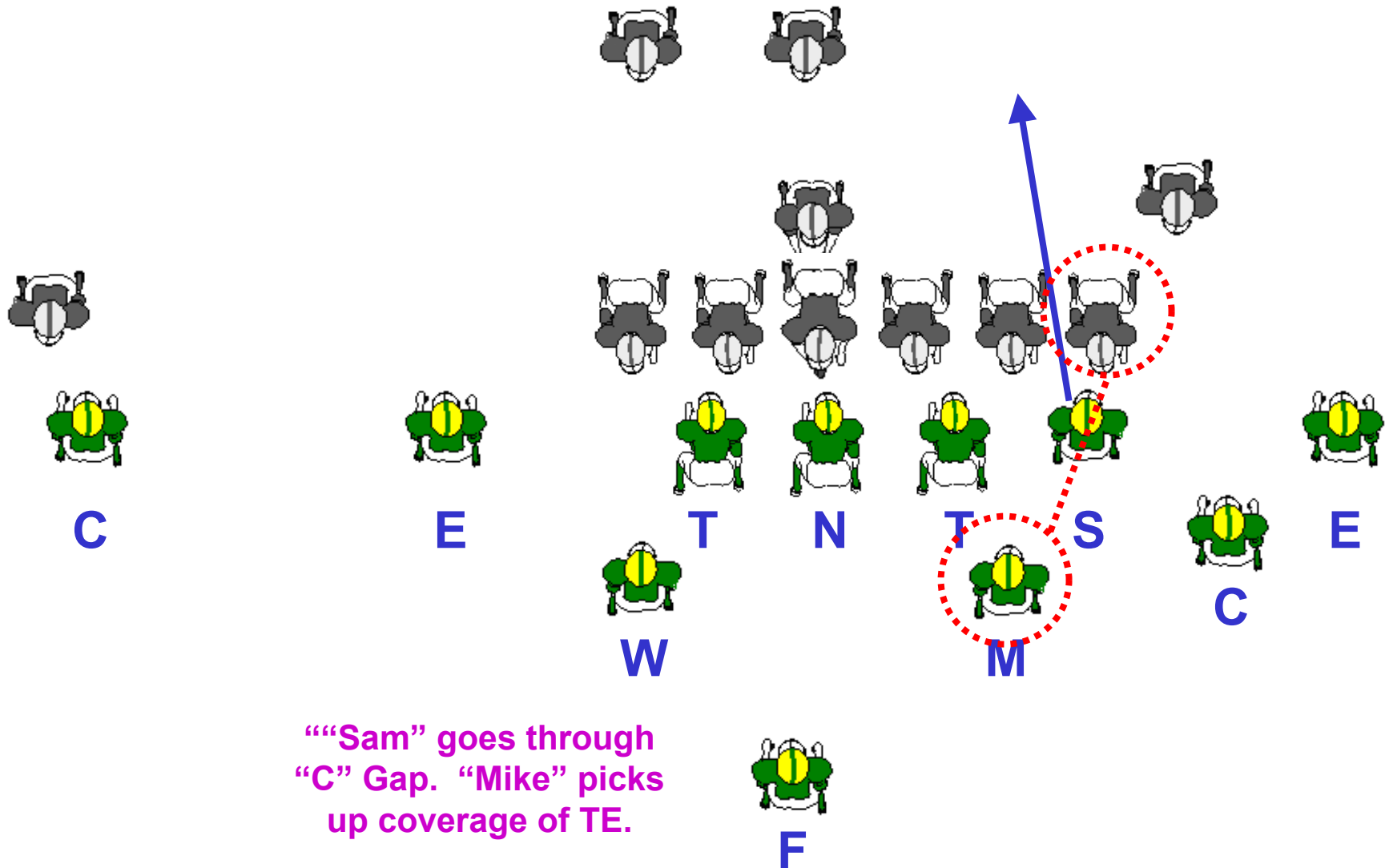

““Sam” goes through
“C” Gap. “Mike” picks
up coverage of TE.

“Max” Call Wing-T Offense

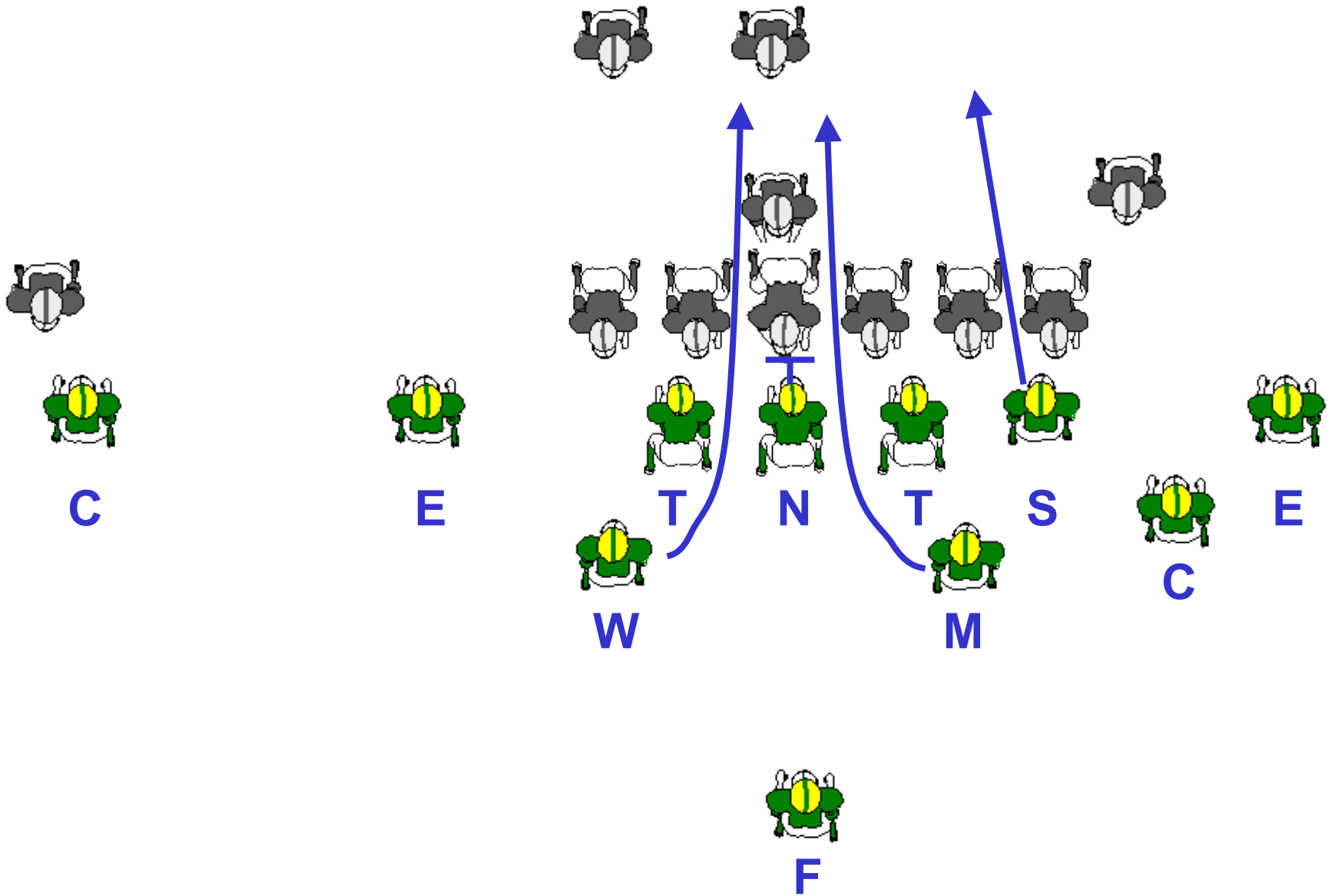

“Fred” Call Wing-T Offense

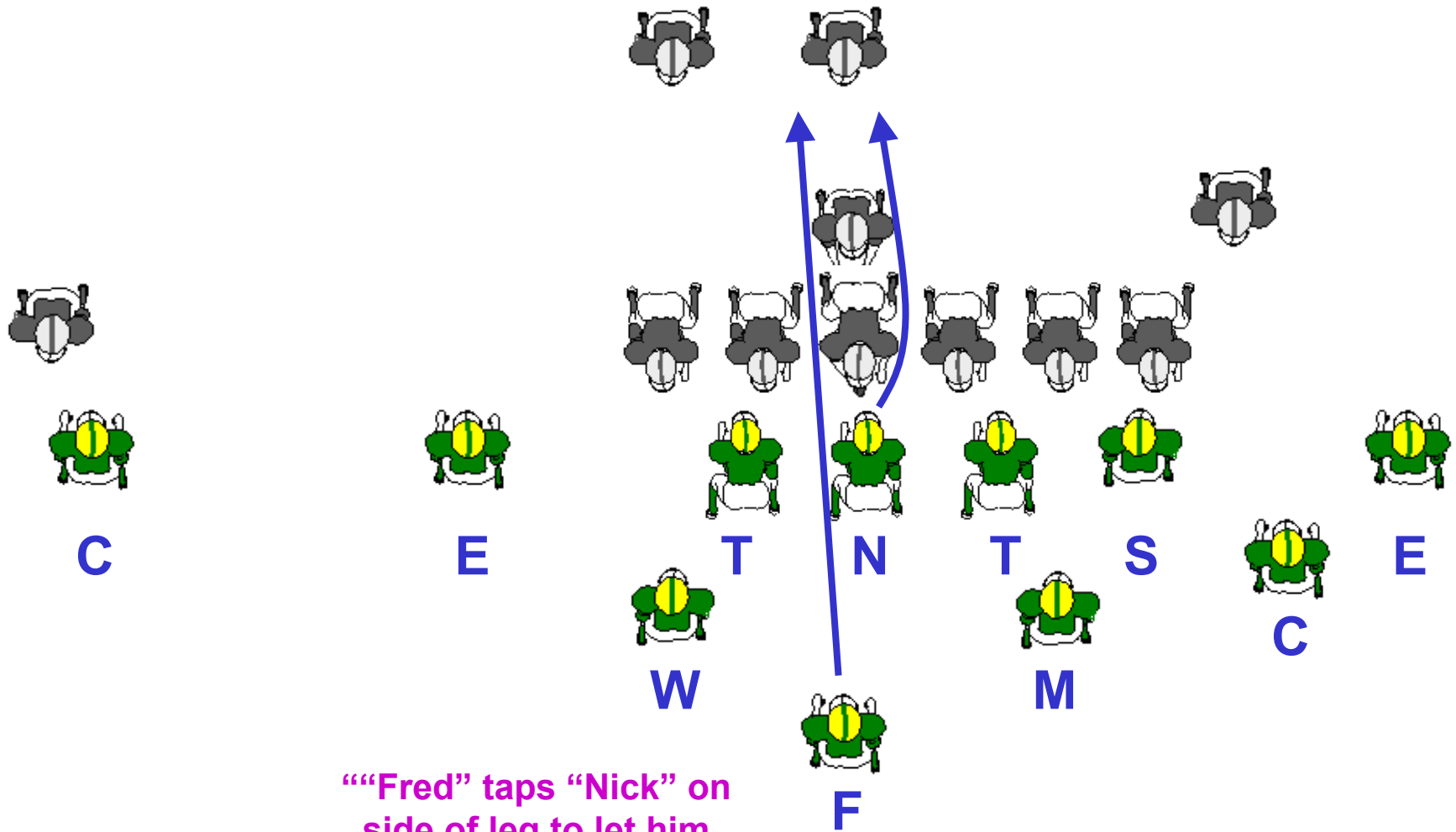

“Fred” taps “Nick” on side of leg to let him know which side he will be blitzing through.

“Freak” Call Pro-Set Offense

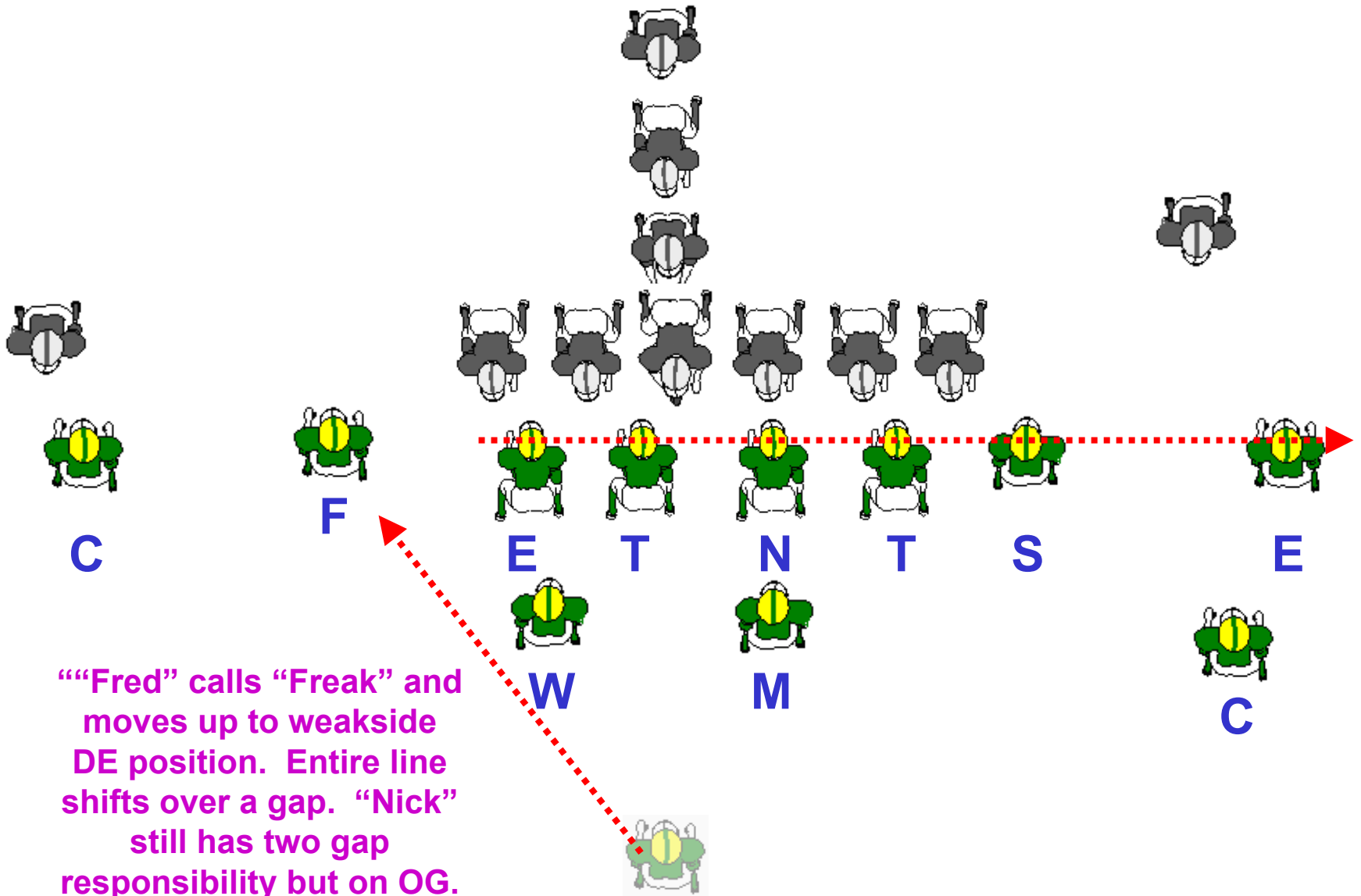

“Fred Gambler” Call Pro-Set Offense

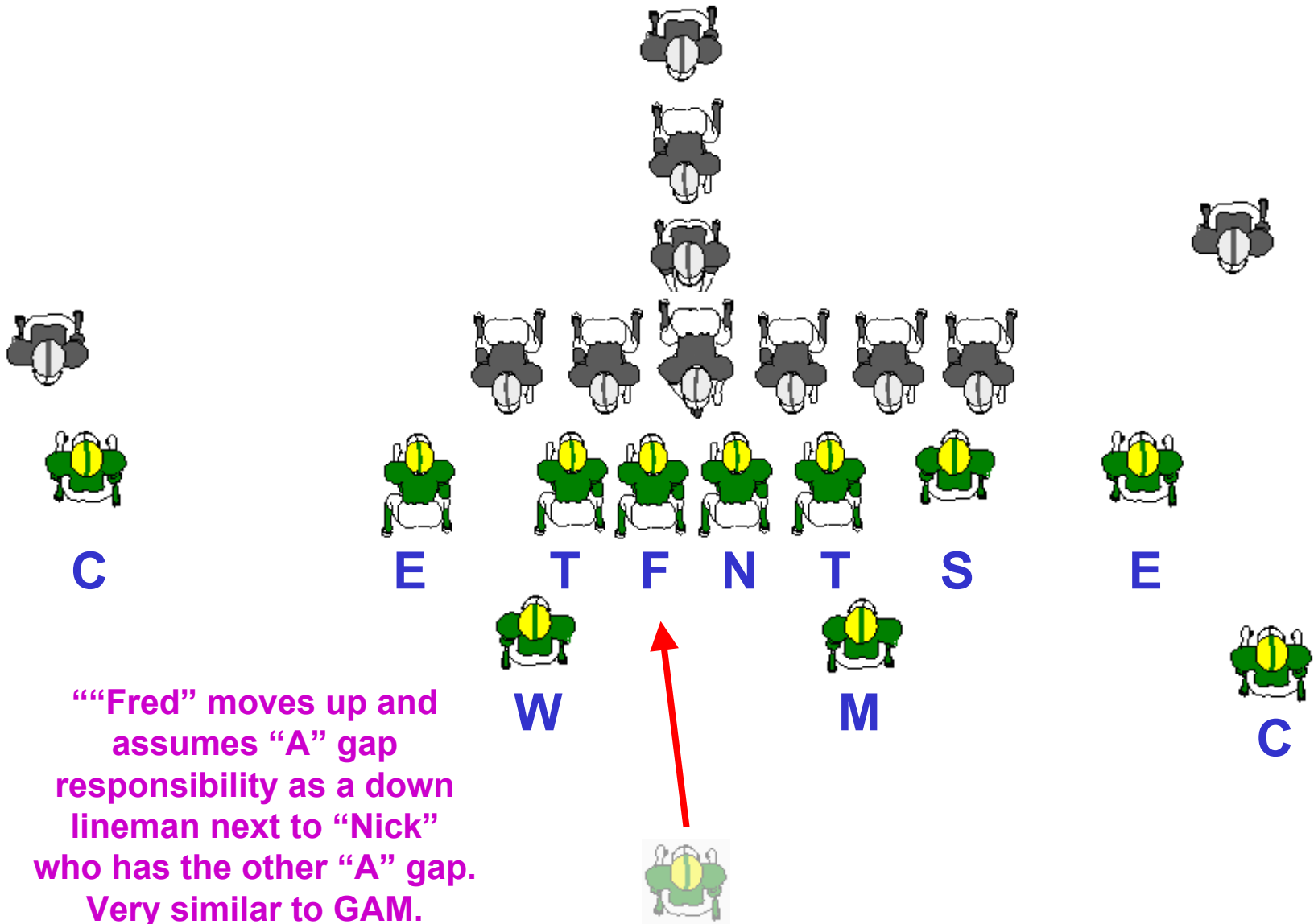

“Fred” moves up and assumes “A” gap responsibility as a down lineman next to “Nick” who has the other “A” gap. Very similar to GAM.

“Mike Gambler” Call Pro-Set Offense

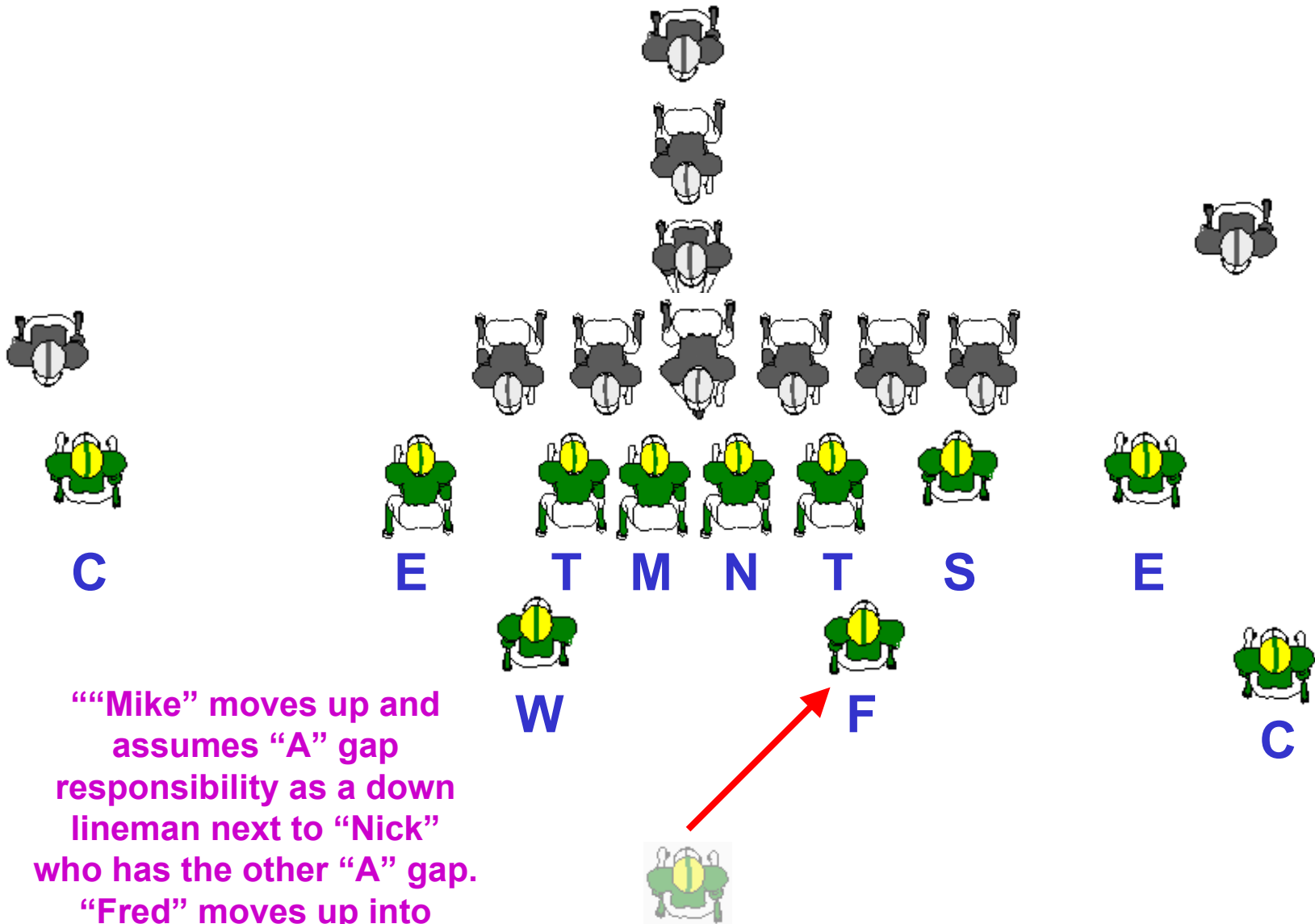

“Mike” moves up and assumes “A” gap responsibility as a down lineman next to “Nick” who has the other “A” gap.
“Fred” moves up into “Mike’s” previous position.

“Will Gambler” Call Pro-Set Offense

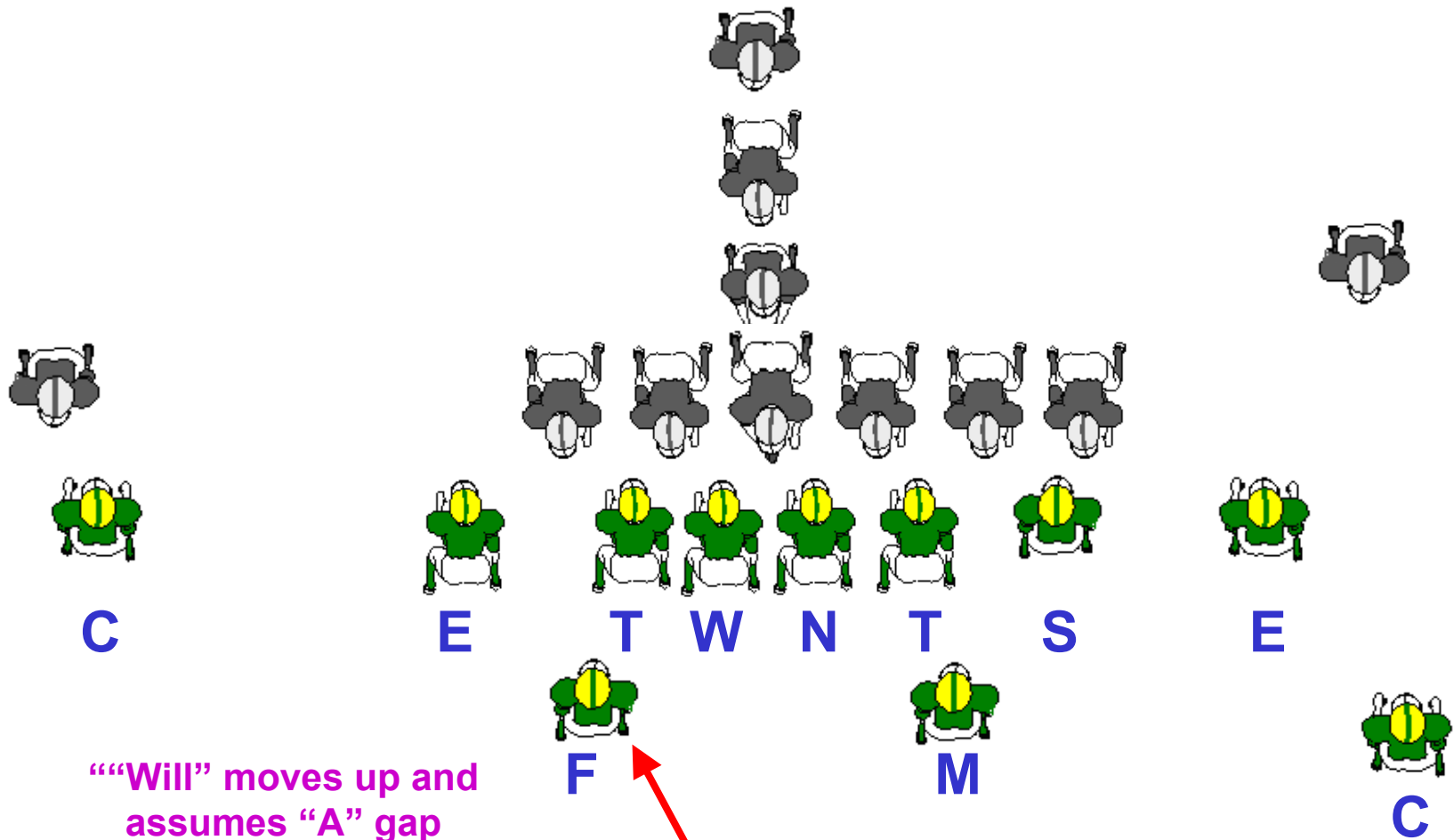

“Will” moves up and assumes “A” gap responsibility as a down lineman next to “Nick” who has the other “A” gap.
“Fred” moves up into “Will’s” previous position.

“Gambler” Call Two Tight End Offense

